

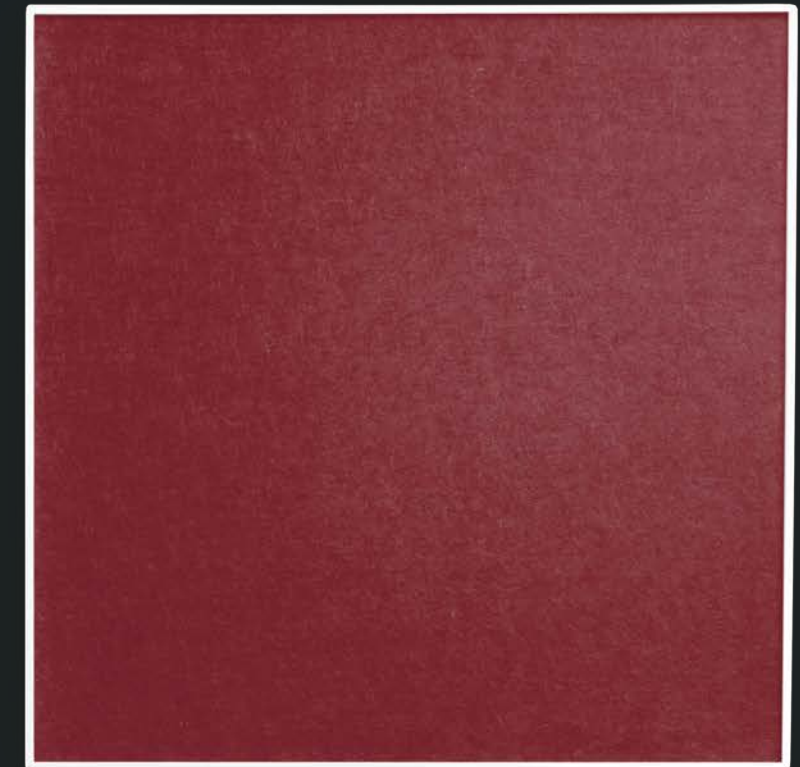

# ACOUSTIC SOLUTIONS

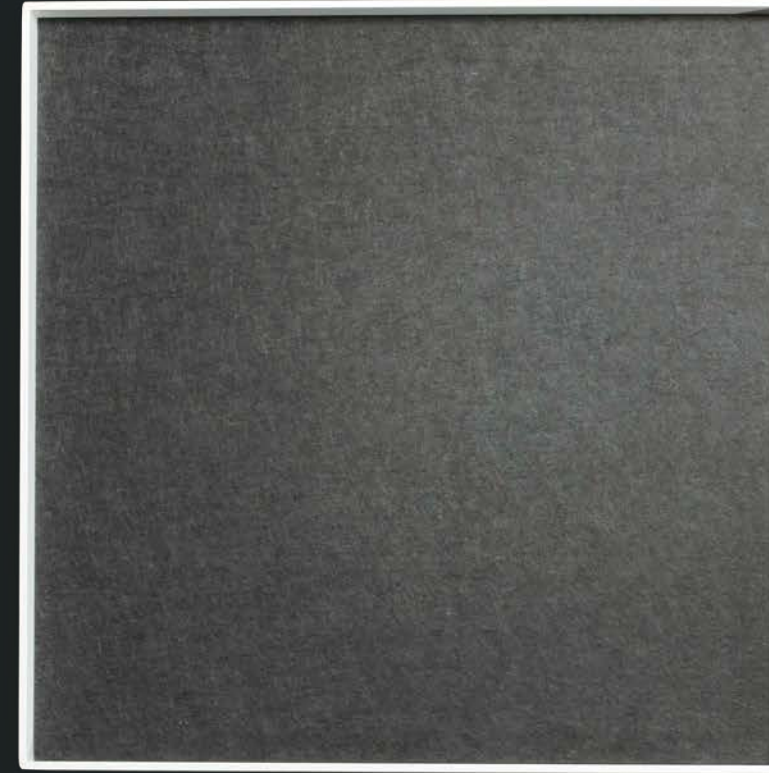

# QUIETLY COLLABORATE

Pinnacle Architectural Lighting  
now offers Acoustic Solutions in  
EDGE, FINA, and LiFT form factors.



# THE (NOISY) PROBLEM



Open Office spaces have created a big buzz and promote collaboration.



Less walls = more ambient noise.



Ambient noise means less concentration on a task.



A decrease in employee productivity costs dollars.

# THE ACOUSTIC SOLUTION

Introducing Acoustic Solutions into your design allows you to light the space and absorb ambient noise with a consistent aesthetic.



# PINNACLE ACOUSTIC SOLUTIONS

Each Pinnacle Acoustic Solution is available with illuminated and non-illuminated fixture options. See the Spec Sheets for available standard combinations.

## EDGE



## LIFT



## FINA



# EDGE ACOUSTICS

Pinnacle's EDGE 1, available as an acoustic solution to reduce reverberation time in a space. A simple frame mechanically secures the acoustic panels in place and creates a spacious cavity to effectively trap ambient noise.

- 1 Acoustic Color  
**A14 Nighttime Blue**
- 2 Acoustic Color  
**A19 Bone**
- 3 Acoustic Color  
**A10 Slate**

Apparent NRC Range: 0.55 - 1.85

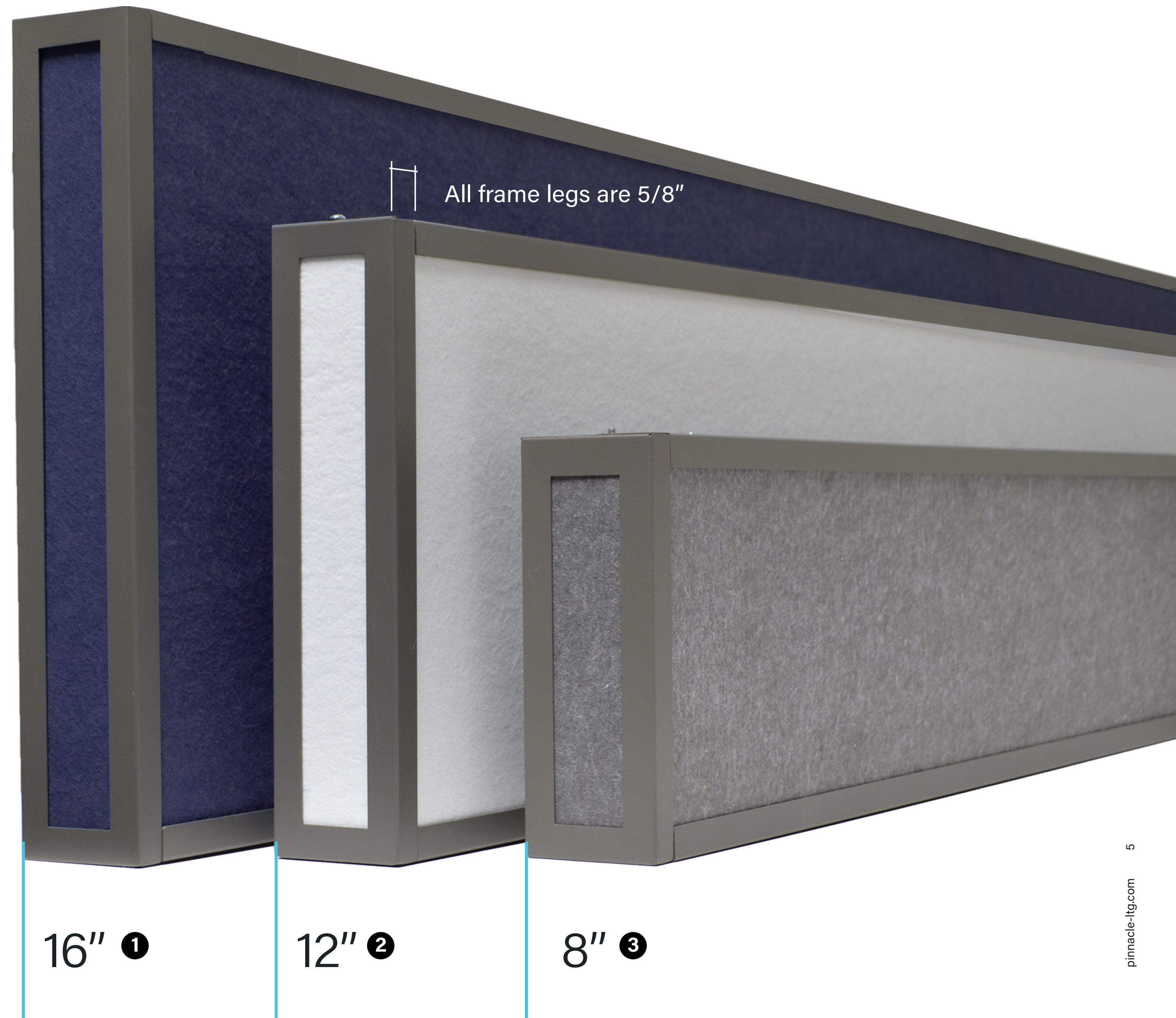

# EDGE ACOUSTICS

## Shielding

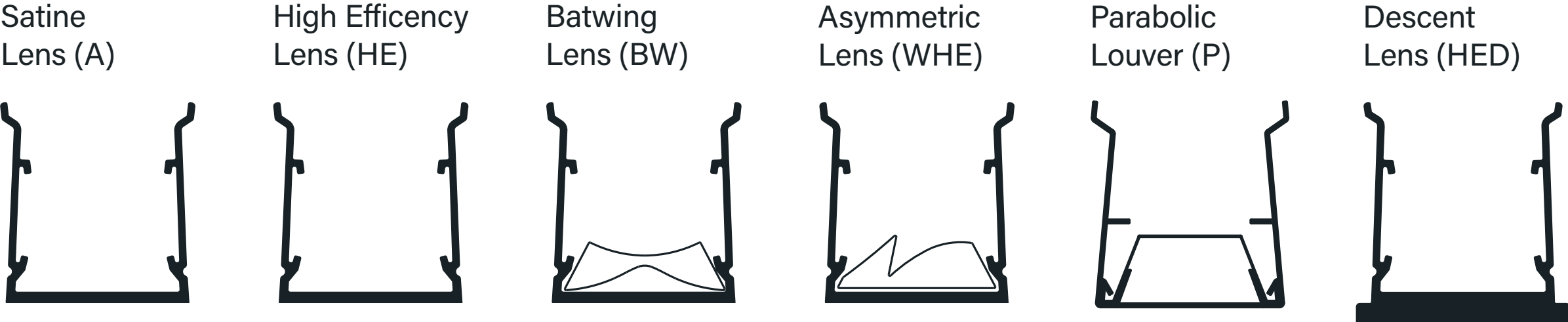

## Housings

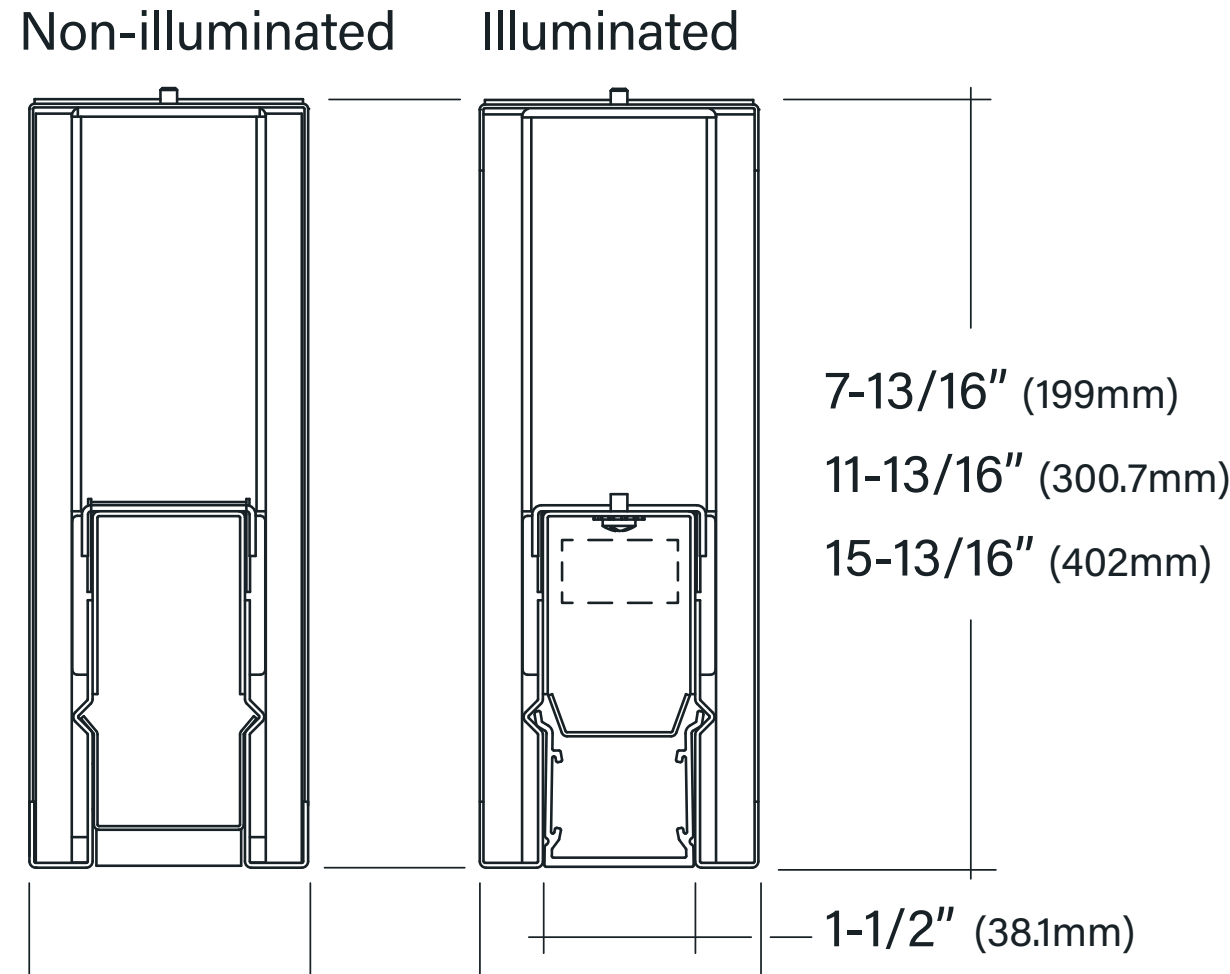

## Lengths

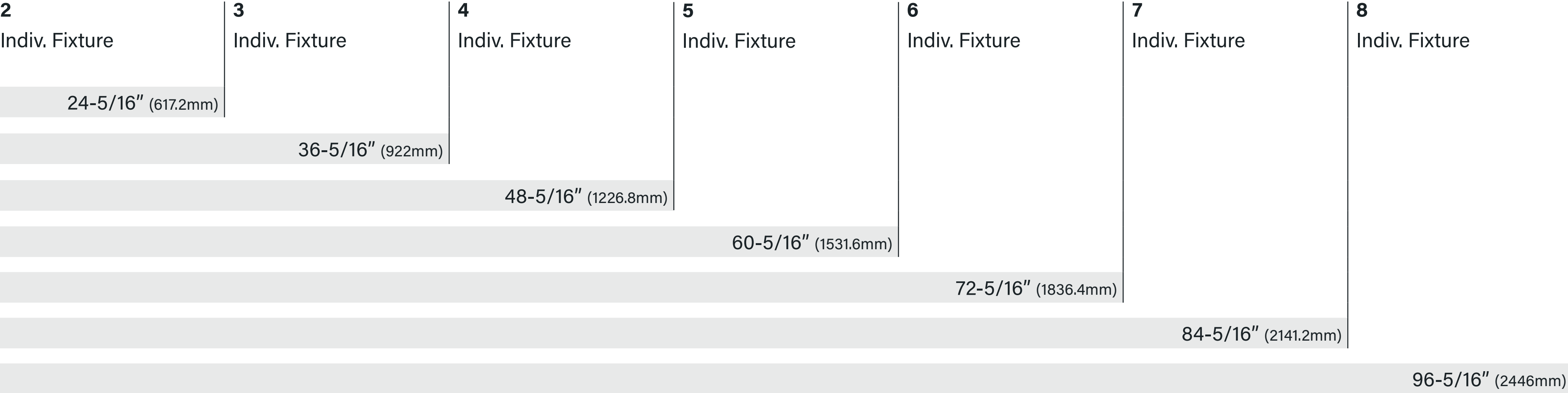



# LIFT ACOUSTICS

Design your space with clusters of light and acoustic fixtures.

## REGRESS

Acoustic Color: P12- Medium Grey



## FLUSH

Acoustic Color: P12- Medium Grey



Apparent NRC Range 0.5 - 1.7



LiFT's six different fixture profiles are available to be suspended, recessed, or surface mounted in both ceiling and wall applications.

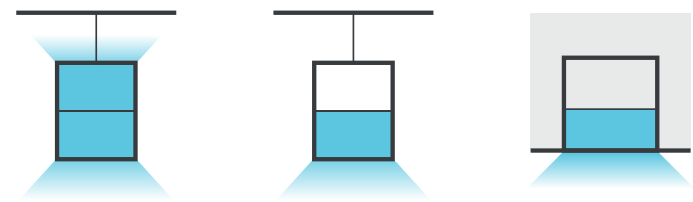

### Housing Heights

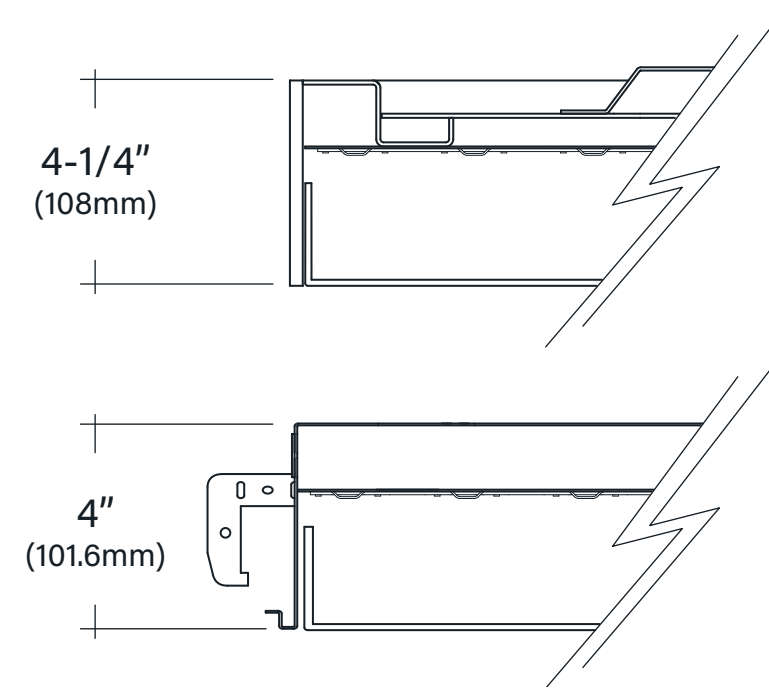

### Housing Sizes

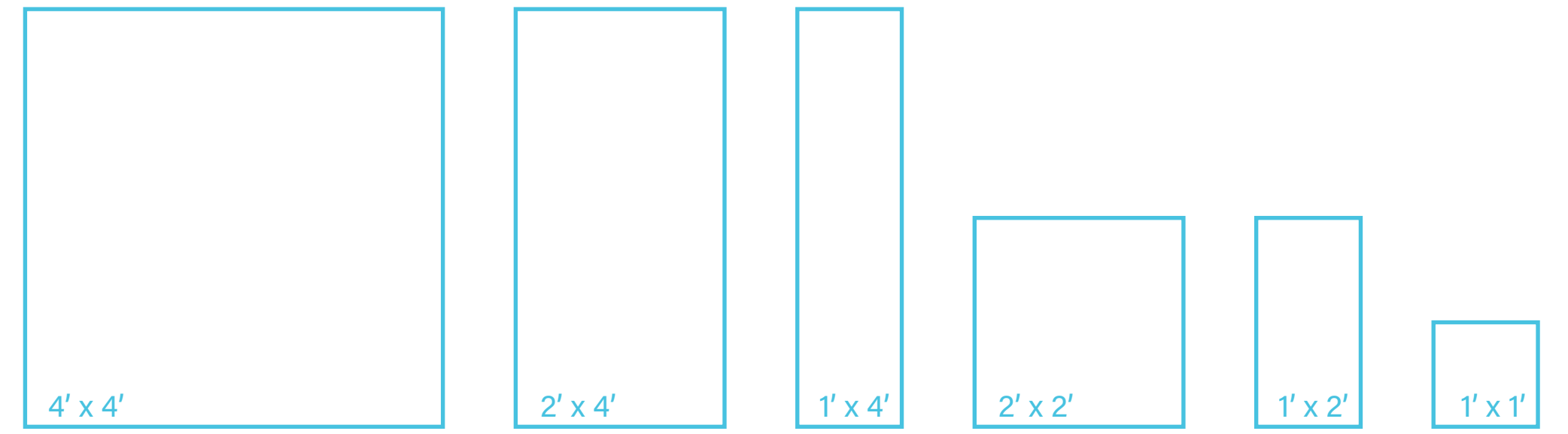

### Shielding

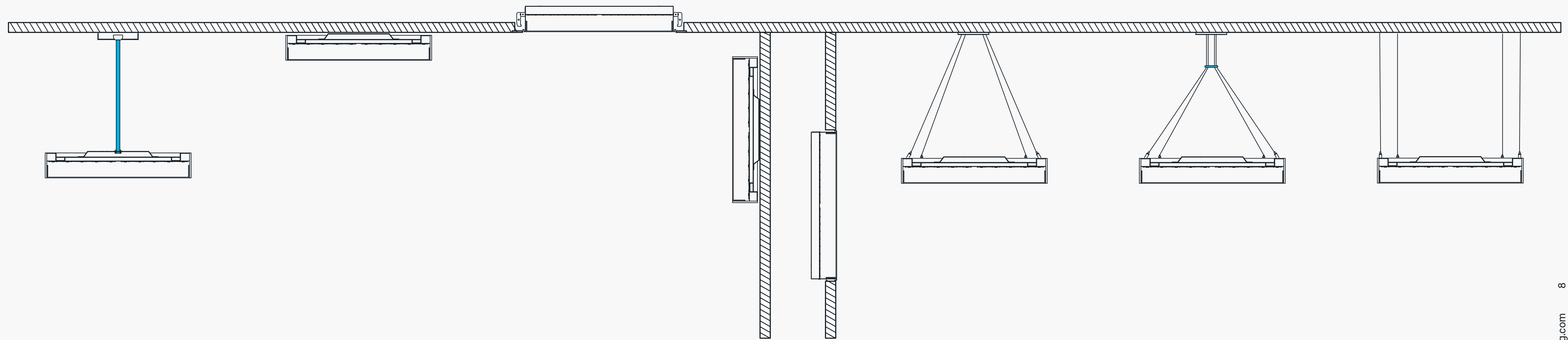

Pendant Pipe, Surface ceiling, Recessed ceiling, Surface wall

Recessed wall, 4 cable AC, 4 cable AC with Hub, 4 cable straight AC







# FINA ACOUSTICS

FINA's thin housing profile and smooth curves are perfect when illuminated or with an acoustic solution.

## REGRESS

Acoustic Color: P12- Medium Grey

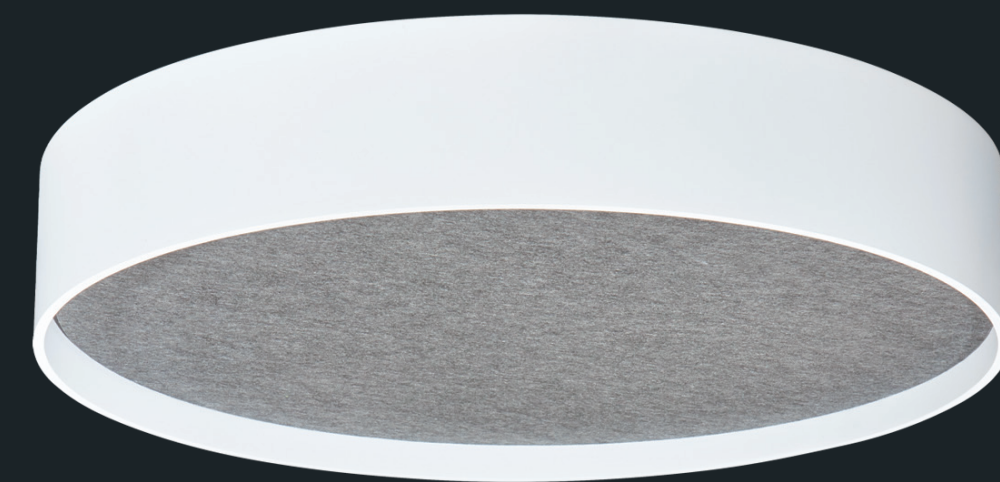

## FLUSH

Acoustic Color: P12- Medium Grey



Apparent NRC Range 0.65 - 1.8

FINA's five different Acoustic fixture profiles can be recessed, surface mounted, and suspended. Specify 3 aircraft cables, 4 aircraft cables with a hub, or pendant pipe for the perfect suspended finish.

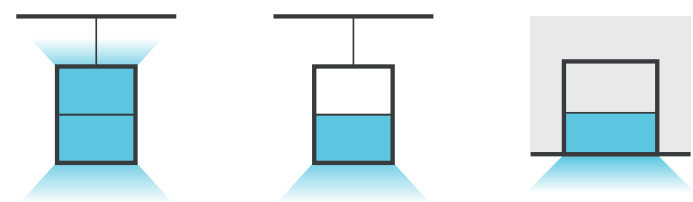

### Housing Heights

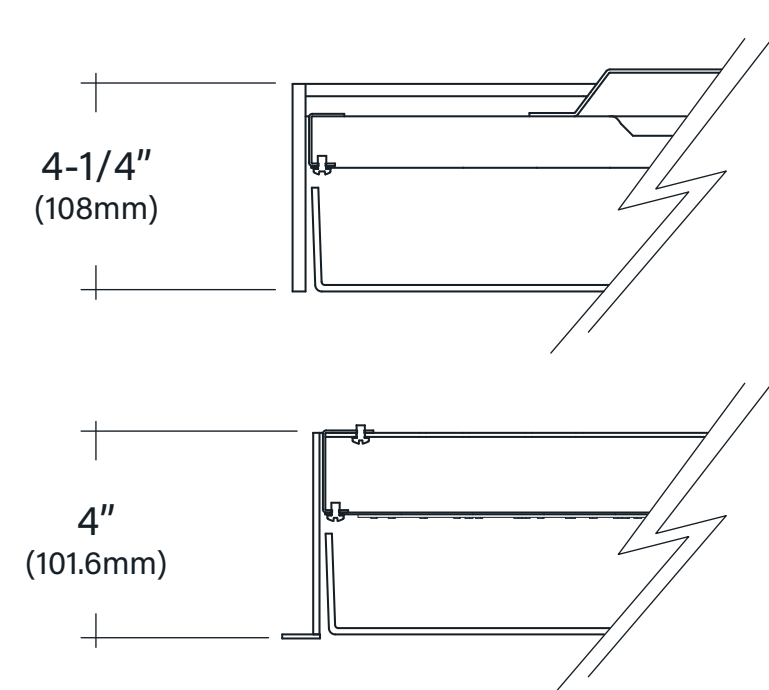

### Housing Sizes

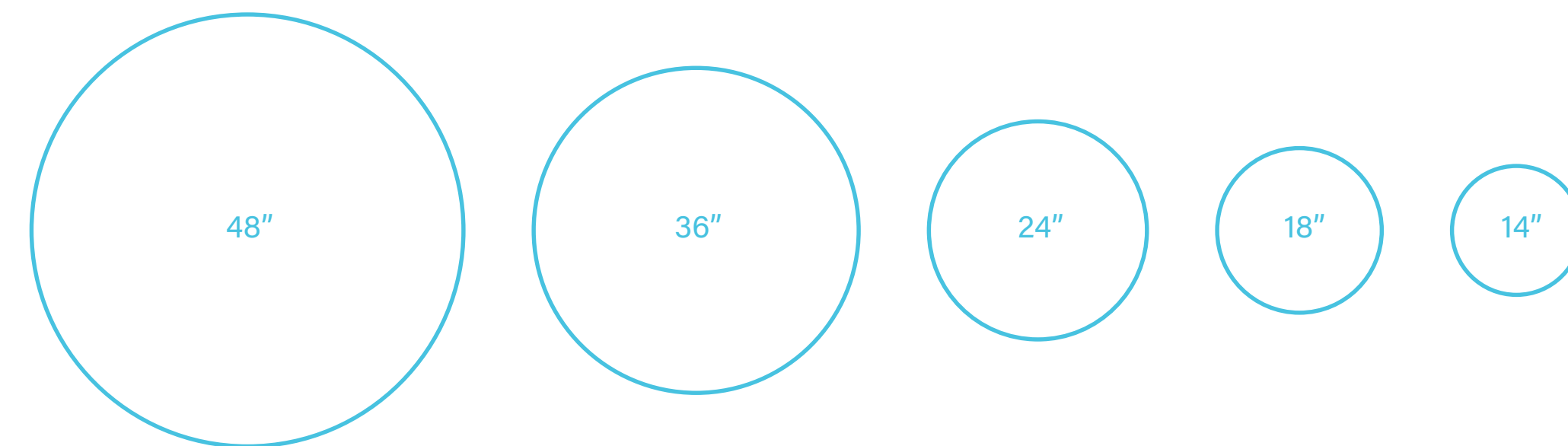

### Mounting

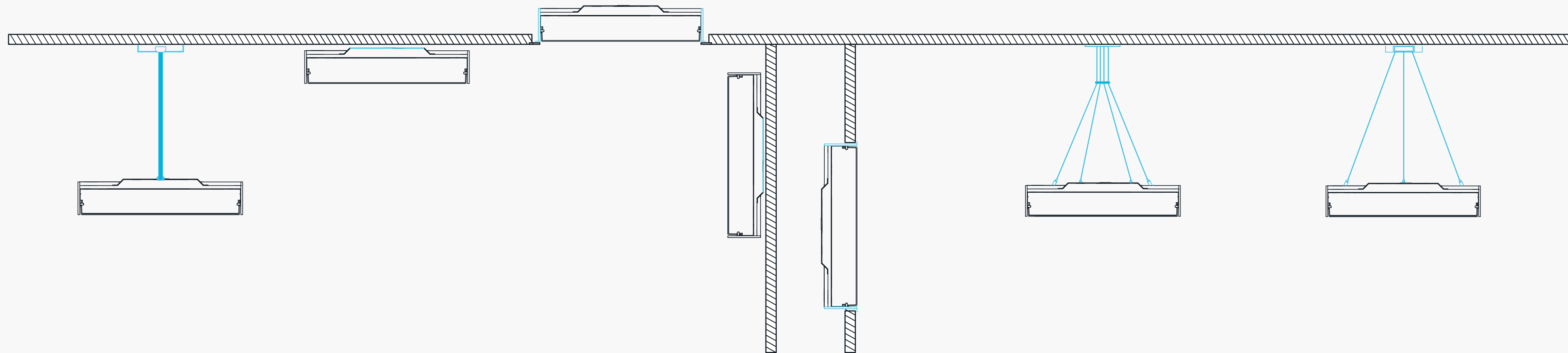

Pendant Pipe, Surface ceiling, Recessed ceiling, Surface wall

Recessed wall, 4 cable AC, 4 cable AC with Hub, 4 cable straight AC



# QUIET IN COLOR

Acoustic Solution panels are available in multiple colors that can subtly affect the mood of the room.

## Custom Color Acoustic Panel (PCC)

Custom color matching options are available. Please note there is a minimum order quantity for custom matching. Consult factory for order quantity, price and lead time.

### Standard Colors



Images are for representation only and may not accurately show color and texture. Please contact Pinnacle for sample.



# ACOUSTIC APPLICATIONS

**ACOUSTIC [ uh-koo-stik ]:** the properties or qualities of a room that determine how sound is transmitted.

Adding in acoustic panels to your design can help eliminate reverberation time and dampen loud noise that naturally occurs in open spaces.



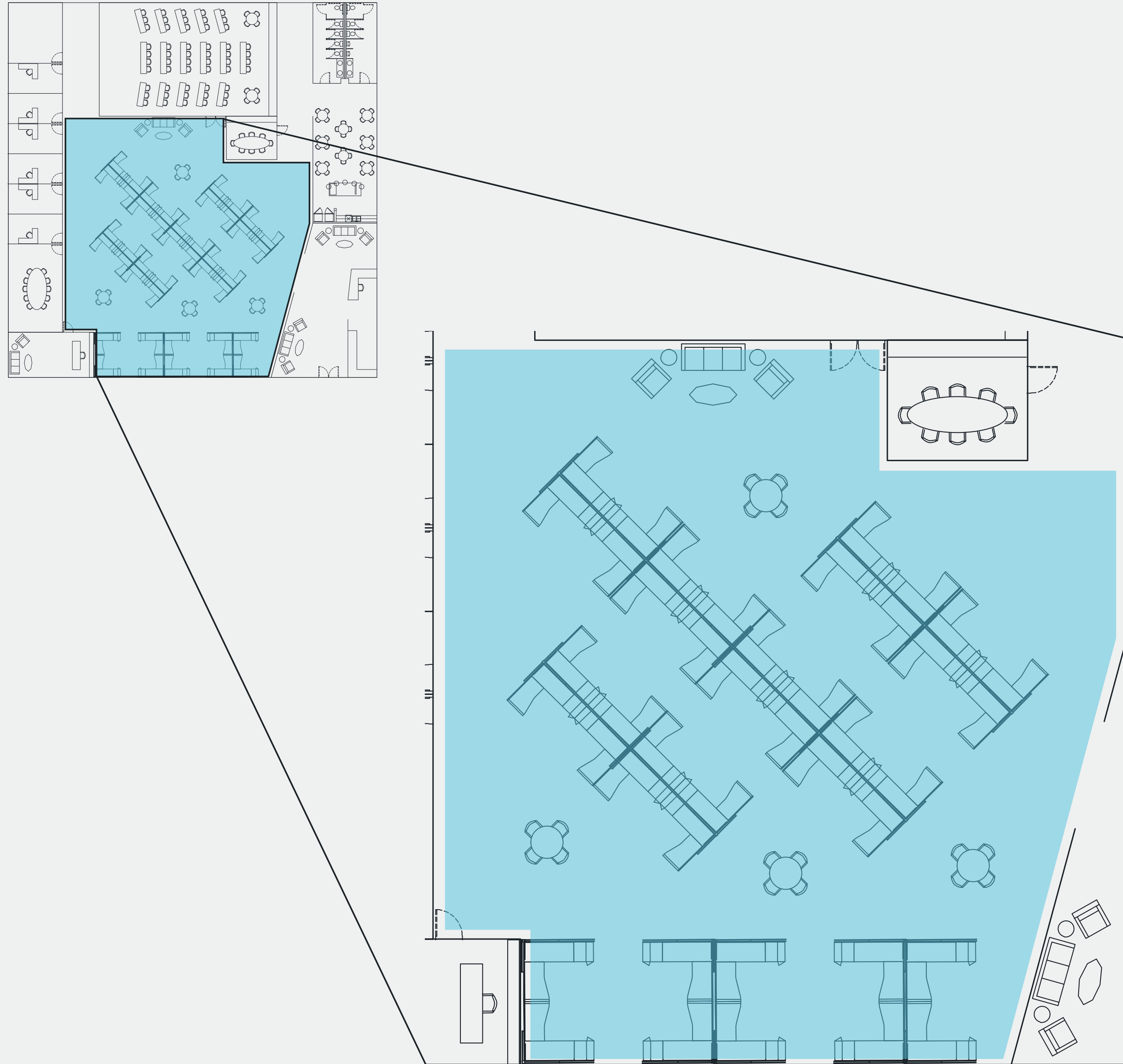

# LOWER THE VOLUME

Acoustic baffles, such as EDGE illuminated and non-illuminated Acoustic Solutions from Pinnacle, are recommended for cavernous locations where echo is an issue. This could be an application such as an open office, multiple-storied lobby areas, or a space with ceilings more than 16' in height.



# LOWER THE VOLUME

In general, covering about 35% - 40% of a ceiling space with acoustic material will reduce echo and reverberation. FINA and LiFT fixtures with Acoustic Solutions are the perfect surface area to place in applications such as long cavernous corridors, conference rooms with little absorptive material, and private offices.

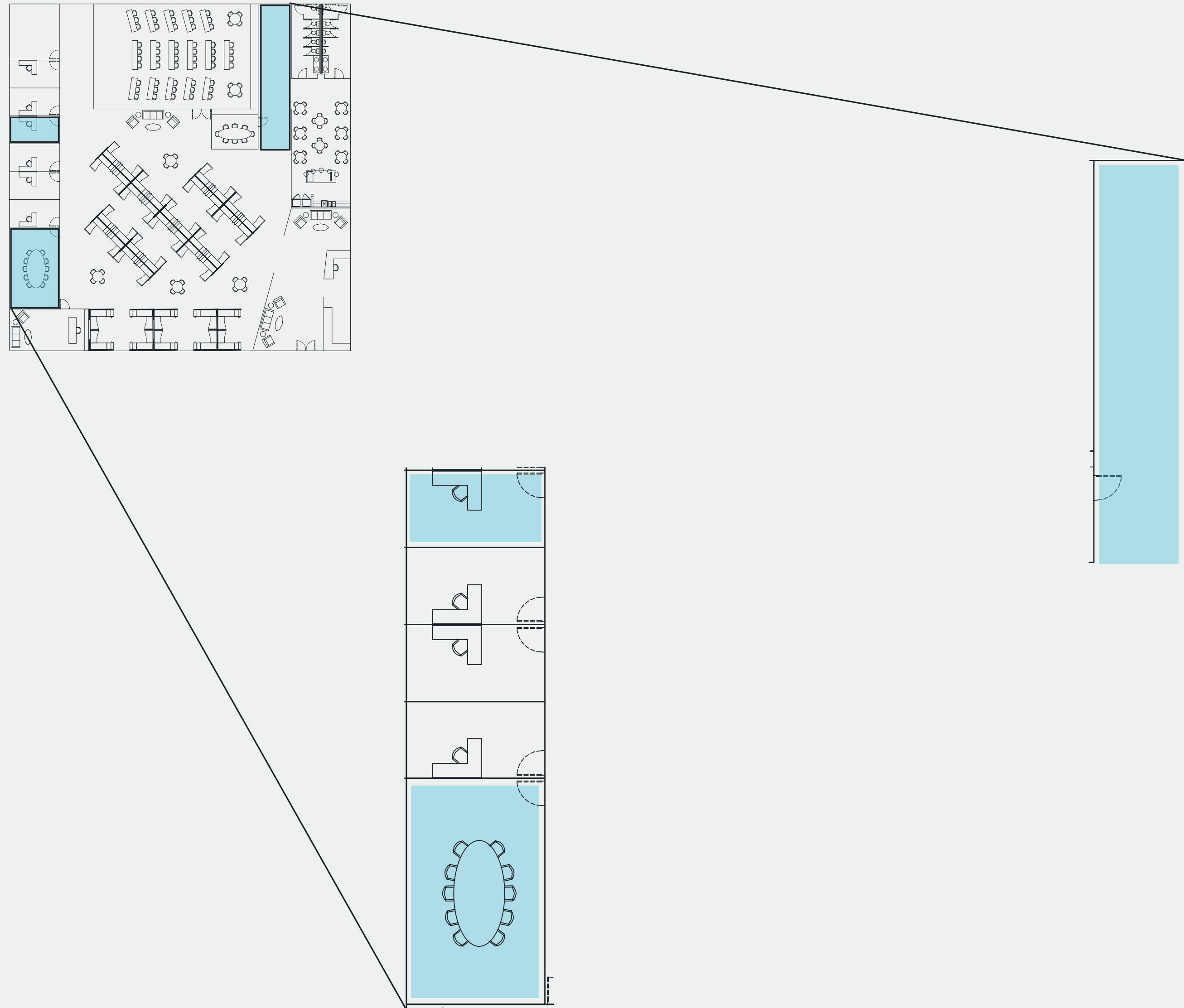
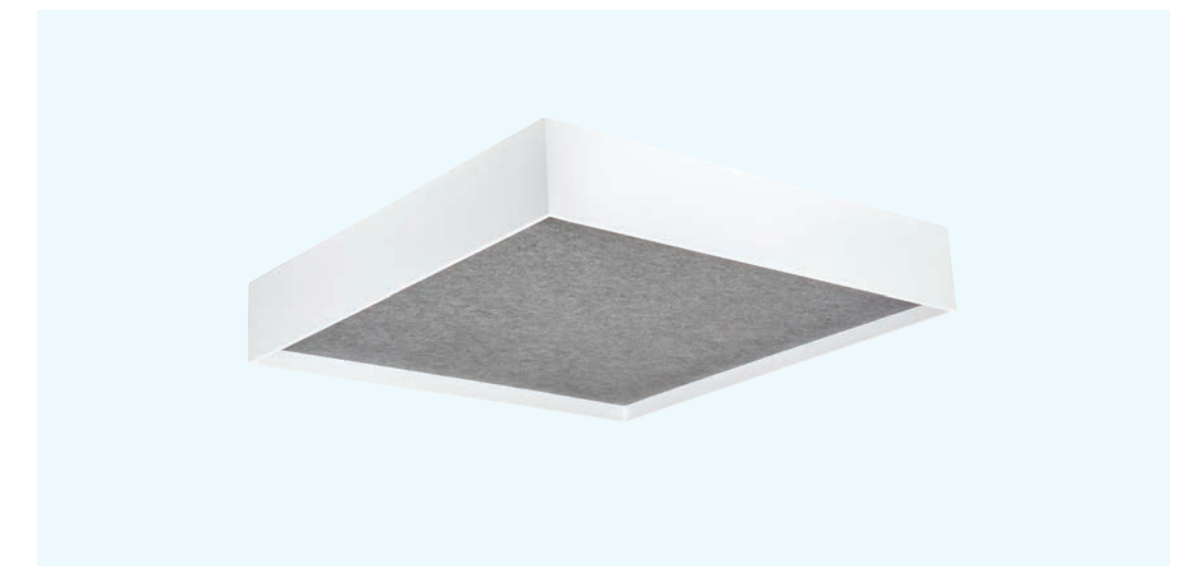

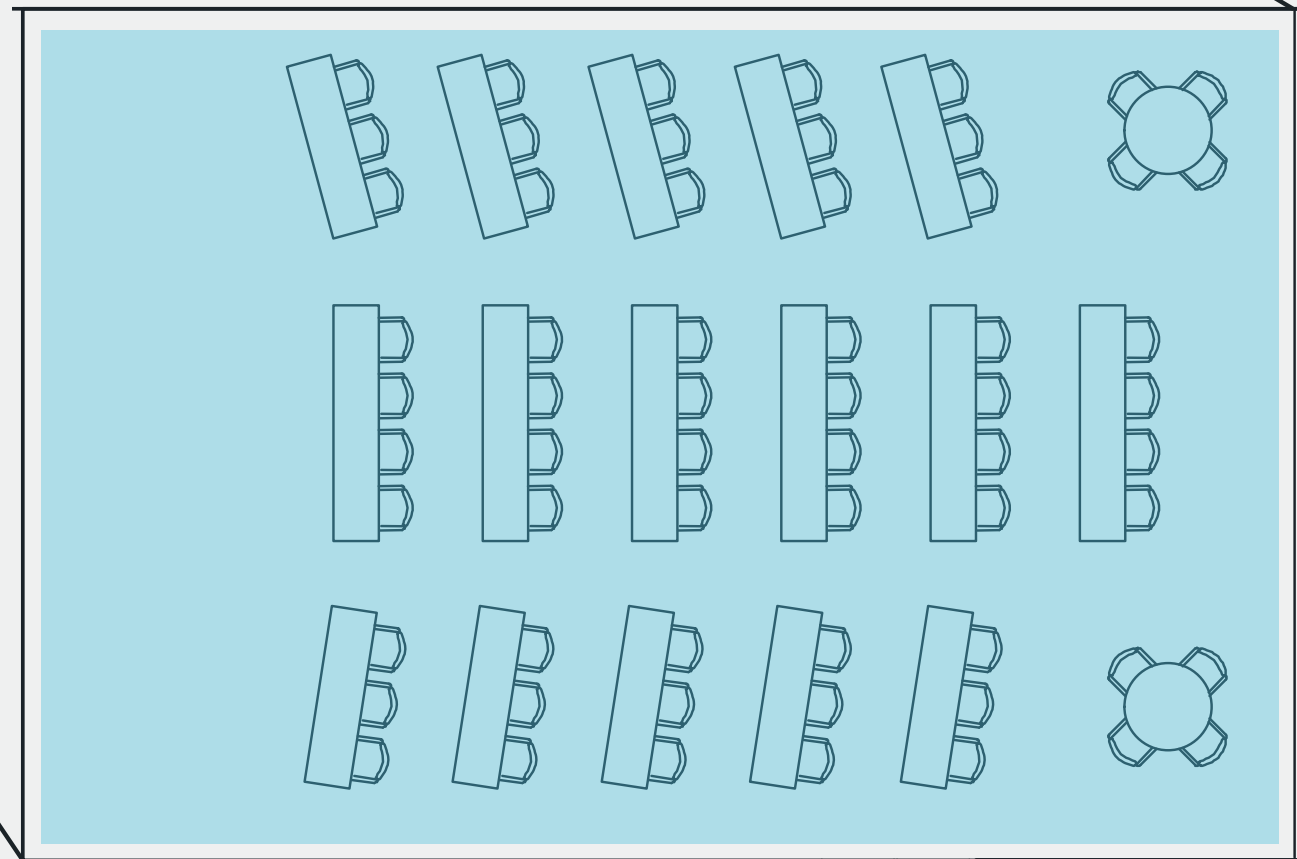
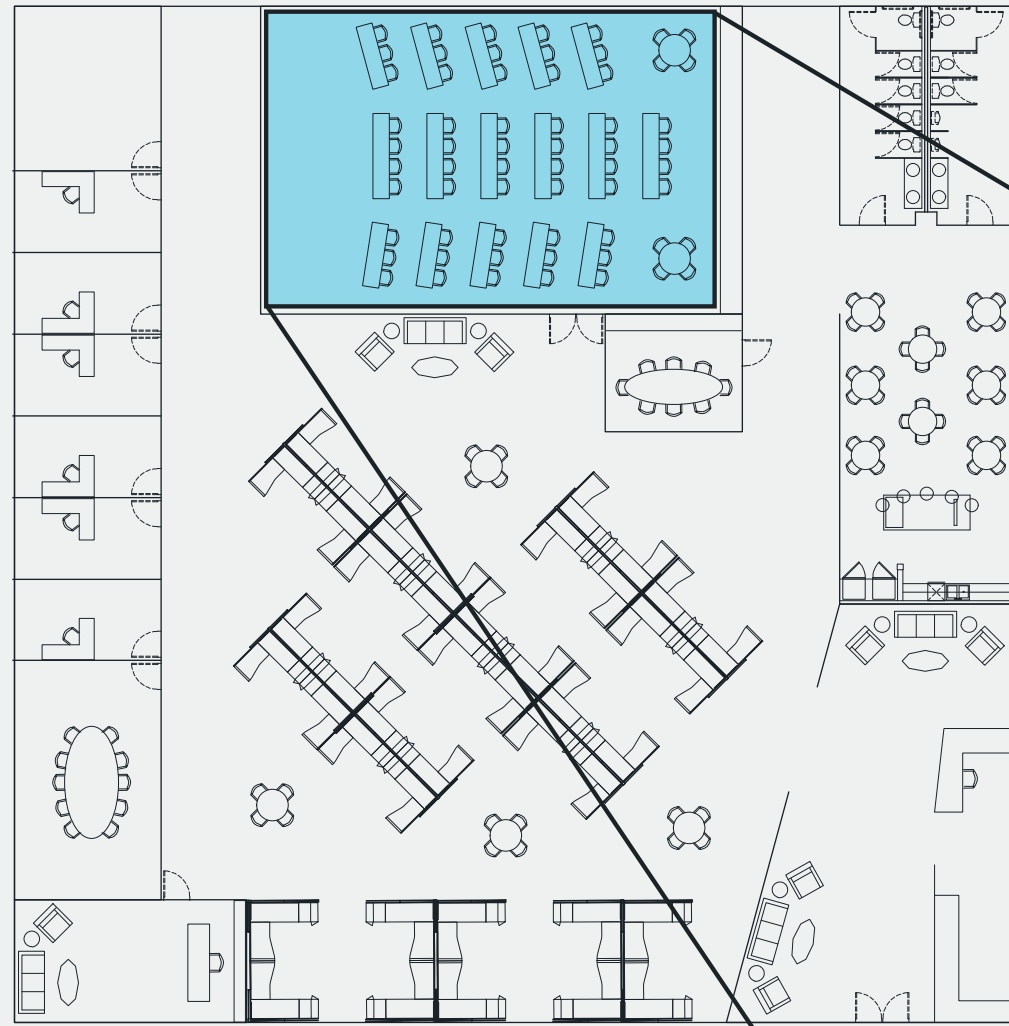

# LOWER THE VOLUME

Mounting a cluster of Acoustic Solutions across from a TV in a large conference room will help reduce echo in a small space. Keeping the center of the cluster at average ear height of the occupants is ideal for this application.



# PERFORMANCE THAT WHISPERS

The following graphs showcase the effectiveness of the Pinnacle Acoustic Solutions at different sound frequencies. The sabins/object is the amount of sound in the space that is absorbed by the panels per fixture.

Contact Pinnacle for assistance with your acoustic calculations.

## FINA 48"

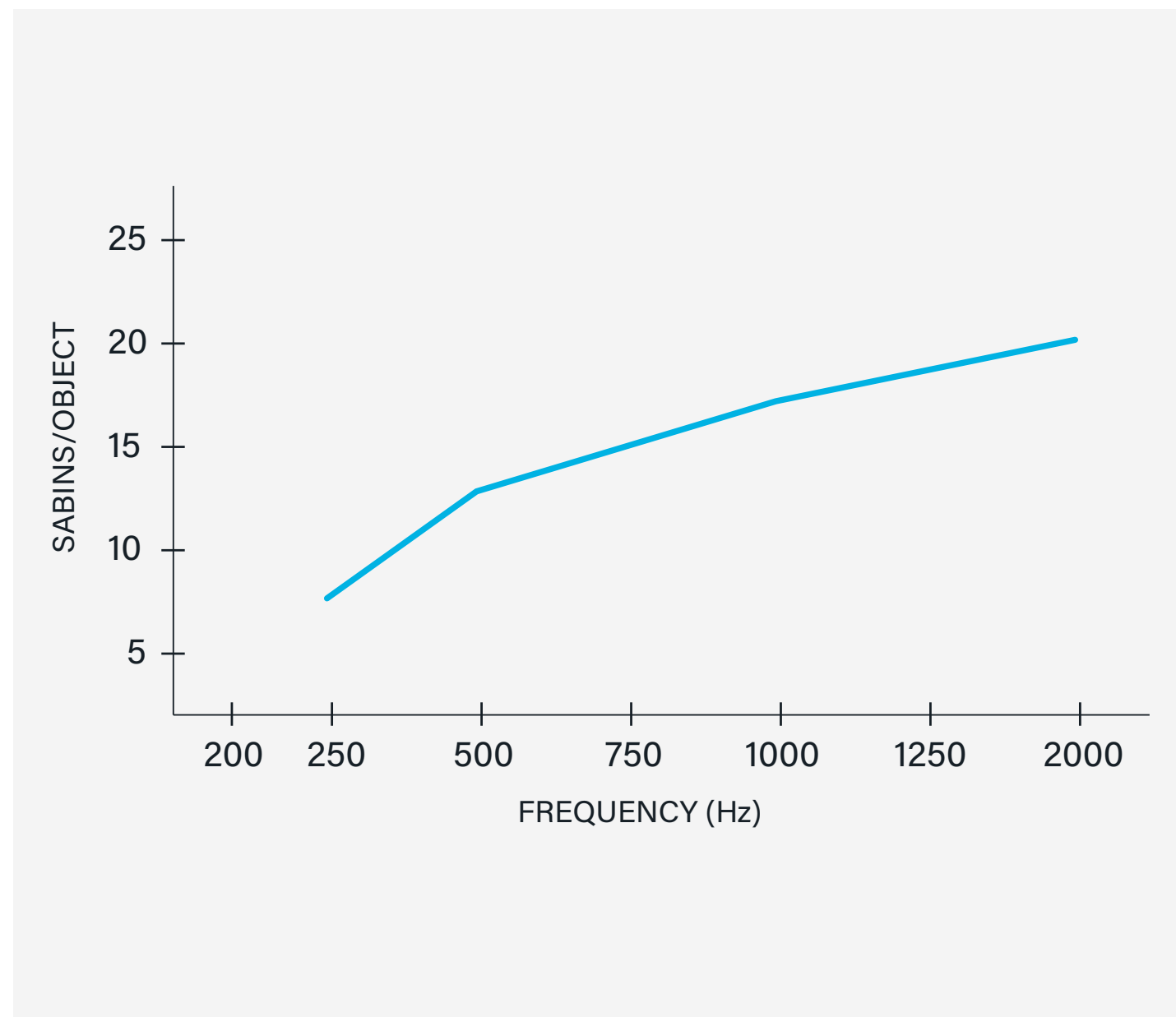

## LIFT 4X4

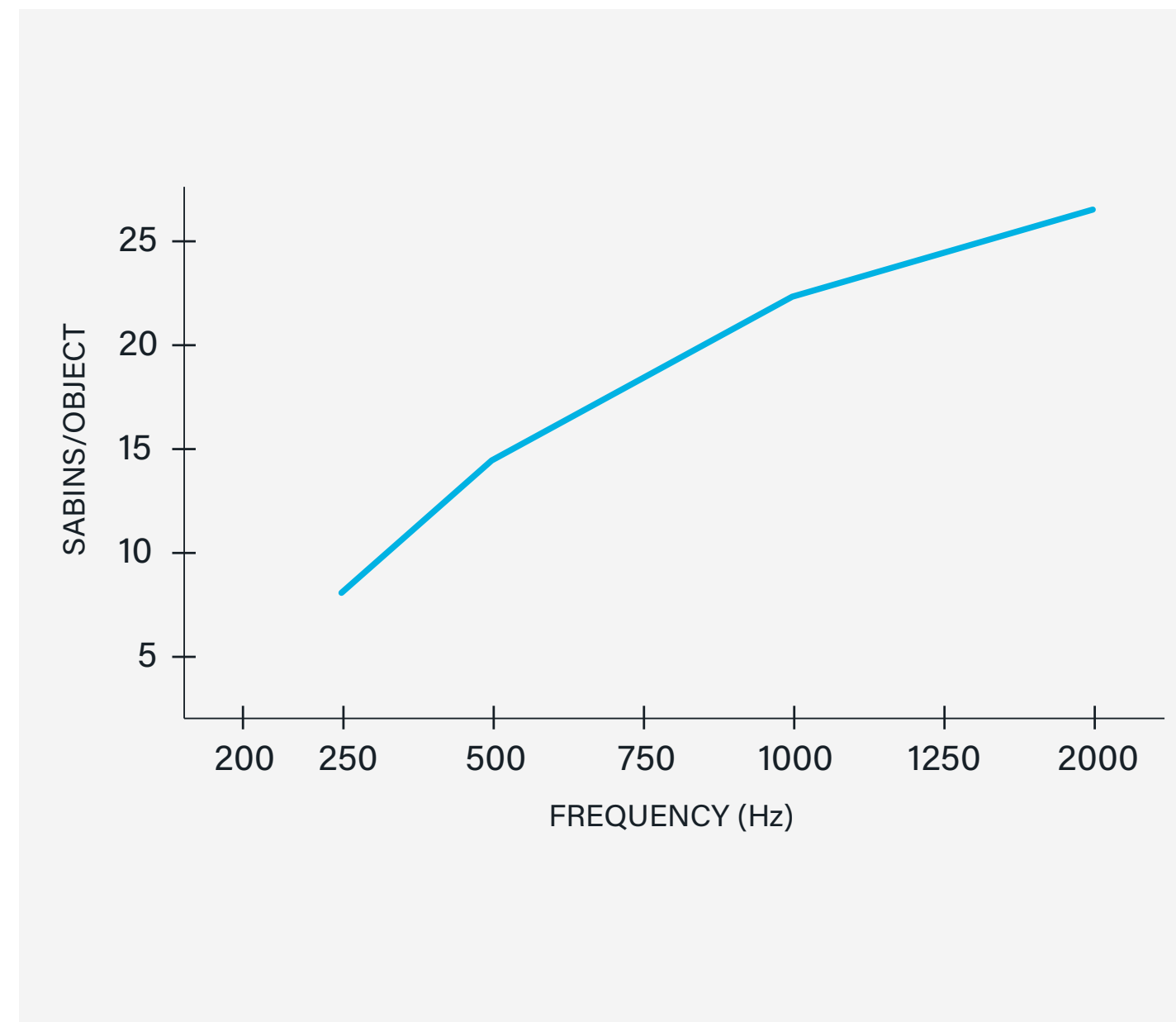

## EDGE 16"

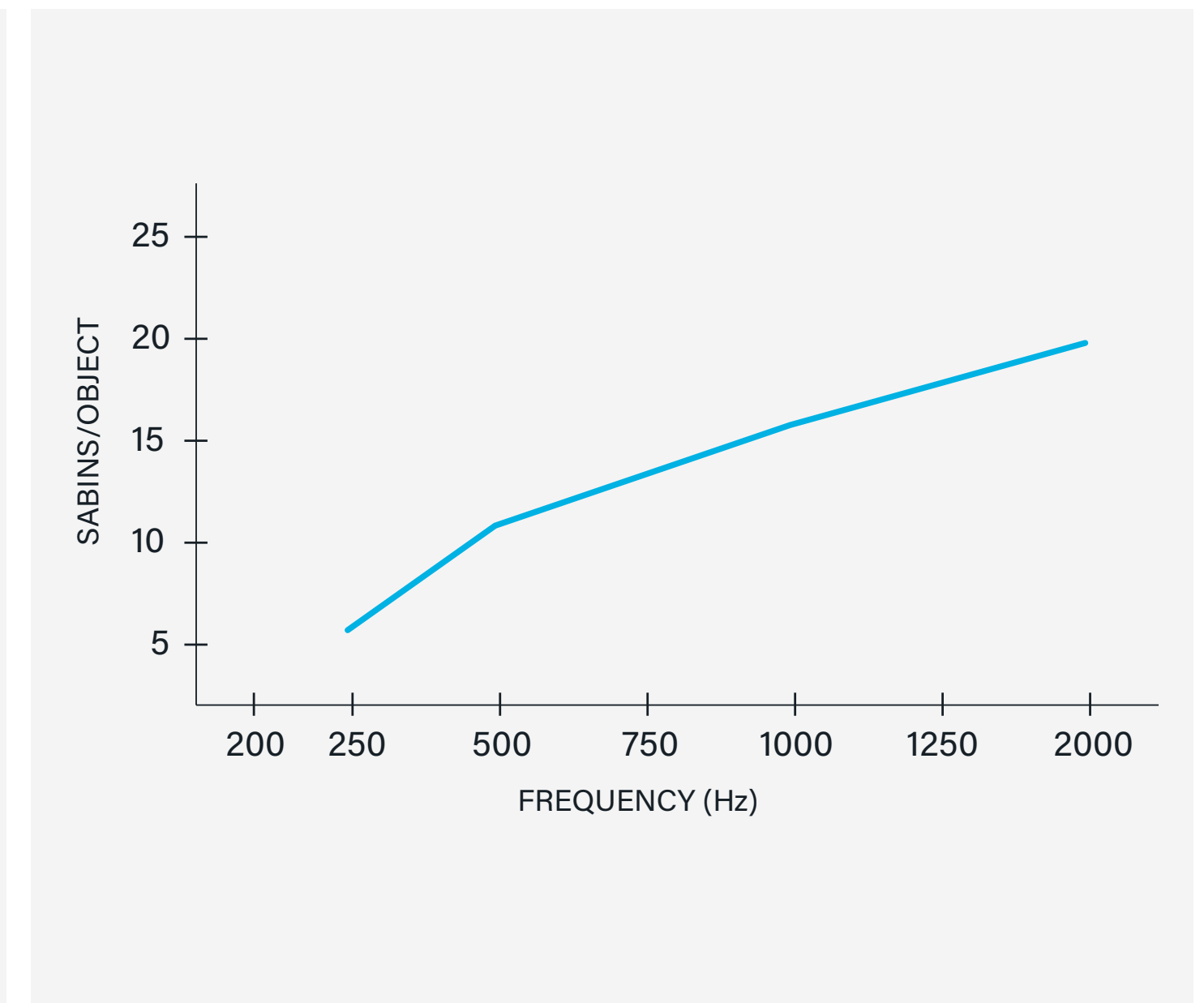



# ACOUSTIC PANEL MAINTENANCE



Acoustic material requires no maintenance but can be easily cleaned if needed. Simple dusting is recommended at the same cadence as other light fixtures in a space. For disinfection, we recommend spraying a solution onto the panels and letting them air dry. Wiping after disinfection is not recommended.

Acoustic panels are covered under the Pinnacle limited 5-year warranty.





**P I N N A C L E**  
ARCHITECTURAL LIGHTING®

3801 Havana St. Denver CO, 80239

Phone: 303.322.5570

[www.pinnacle-ltg.com](http://www.pinnacle-ltg.com)

**December 2020**

© 2020 Pinnacle Architectural  
Lighting®

Specifications and dimensions subject to change without notice. Specification sheets and brochures that appear on [pinnacle-ltg.com](http://pinnacle-ltg.com) are the most recent version and supersede all other previously printed or electronic versions.