



EDGE *Wet*

PINNACLE
ARCHITECTURAL LIGHTING®

A brand of  legrand





EDGE WET

BEAUTIFUL INSIDE AND OUT





EDGE WET

Pinnacle Architectural Lighting's EDGE represents the culmination of advances in engineering, design, technology, and performance to offer the most complete product family in the industry. From the LED technology, fully luminous lens, trim detail, to the endless design possibilities of our connector system, no detail was overlooked. The same thoughtful design went into the development of our EDGE Wet. The goal was simple: create a fixture durable enough to withstand the elements while still providing the same clean, smooth lines of an indoor luminaire. Who says you can't have the best of both worlds?

EDGE Wet: beautiful inside and out.

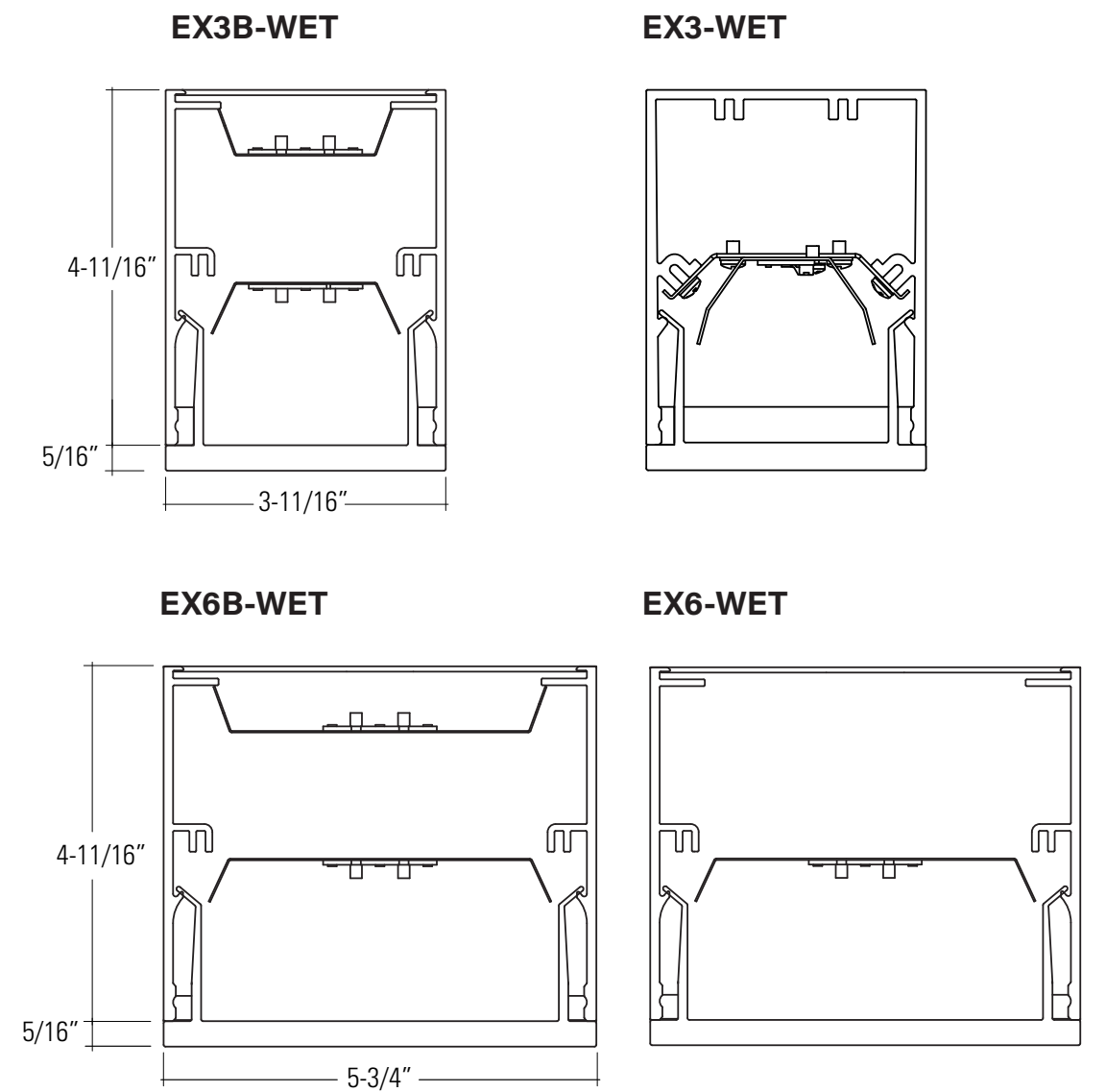

EDGE Wet is available in a 3" and 6" aperture in both direct and bidirectional light distributions. Choose from recessed, wall, surface or pendant mounting options and 4 standard color finishes. Housing is the same for recessed and suspended.



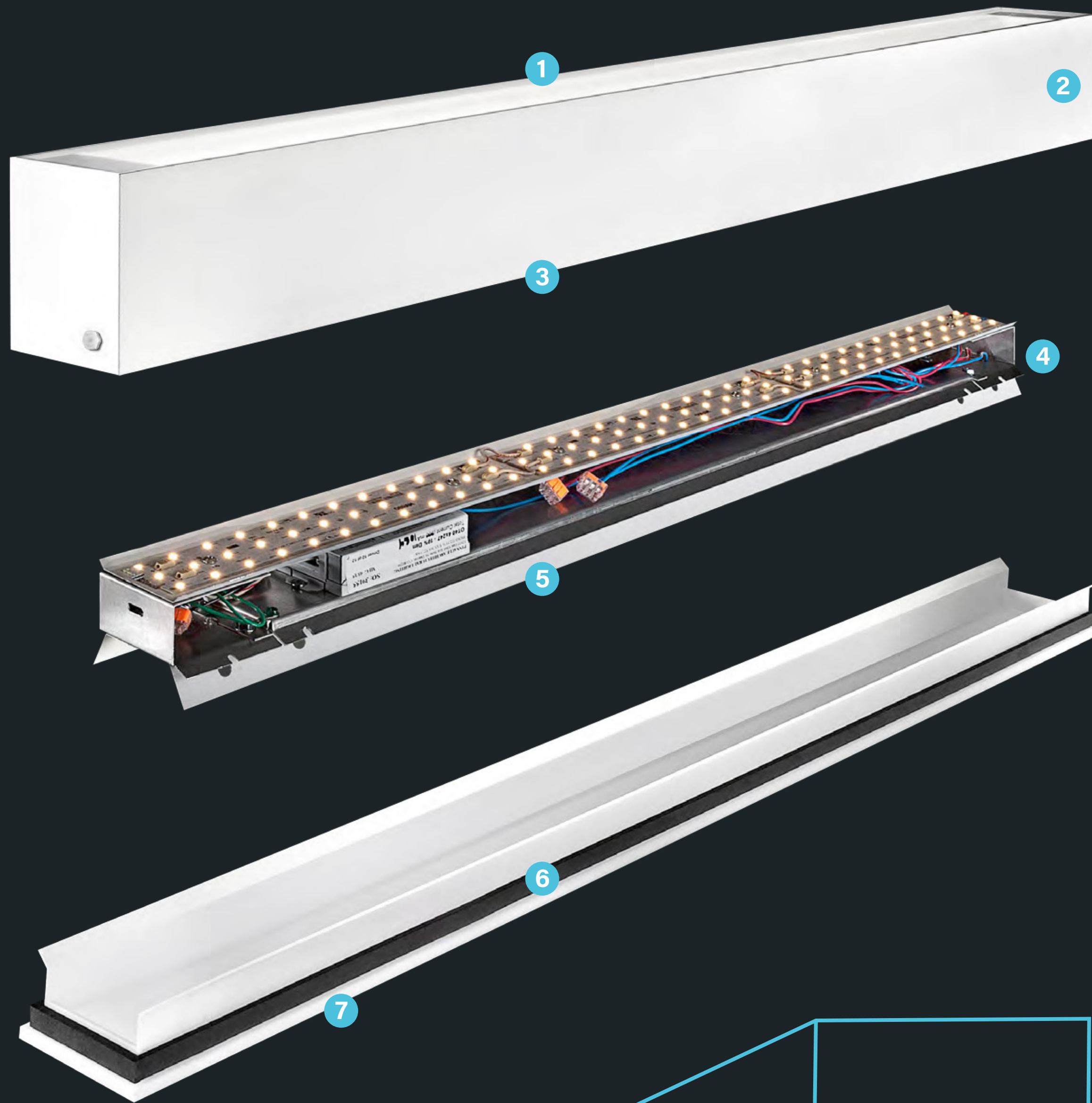

1 WATER RESISTANT

- Bidirectional upright component equipped with an impact-resistant, U.V. stabilized acrylic lens to prevent discoloration
- Lens permanently attached with a watertight seal
- Pressure equalizing vent allows the luminaire to “breathe”, while also preventing moisture build up that can lead to premature damage

2 DURABILITY FIT TO LAST

- High grade extruded aluminum housing covered with a seven step powder-coat finish
- Finish helps protect against the toughest elements, including corrosion
- Chemical and fade resistance ensures longevity

3 CONTEMPORARY DESIGN

- Hardware-free extruded aluminum housing delivers a sleek, contemporary design
- Mirrors the aesthetic of our EDGE indoor product offering

4 SMART SOLUTIONS

- LED optical design and state-of-the-art LED technology combine to create balanced brightness across the lens
- 2700K (CRI 90+), 3000K, 3500K, 4000K (CRI 80+) and 5000K color temperatures available in standard and high output
- 5 year warranty on LED boards and drivers

5 COMPACT COMPONENTS

- All-inclusive module houses LED components in one compact unit
- Unit easily releases from the housing for room-side maintenance

6 INTERNAL COMPRESSION

- Single-piece, gasketed lens securely snaps into the internal walls of the housing
- Silicone gasket compresses once lens is in place to prevent any leaking into the fixture

7 BOLD ELEGANCE

- Fully luminous lens emulates the simple, clean lines of our Edge Evolution interior products
- Quarter inch lens thickness accents the external edges of the lens creating a glowing effect

 Made in the U.S.A.

CONNECTED

EDGE Wet is offered in 7 different fixture lengths, providing design options to meet your project requirements. Available lengths start at 2' and can be specified in 1' increments up to 8' in length.

The individual units can be connected and through-wired creating the appearance of an illuminated path of light. The protective mechanical joint secures the through-wiring while the custom formulated gasket seals the connection watertight.

...All with a minimal reveal of less than 1/8"



EDGE Wet is a UL Wet label product with an IP65 rating on the 6" version and an IP66 rating on the 3" version, with an IK10 rating on both sizes. For added assurance, Pinnacle Lighting performed both a salt spray test and an accelerated weather test to ensure the product components' durability in an outdoor setting.

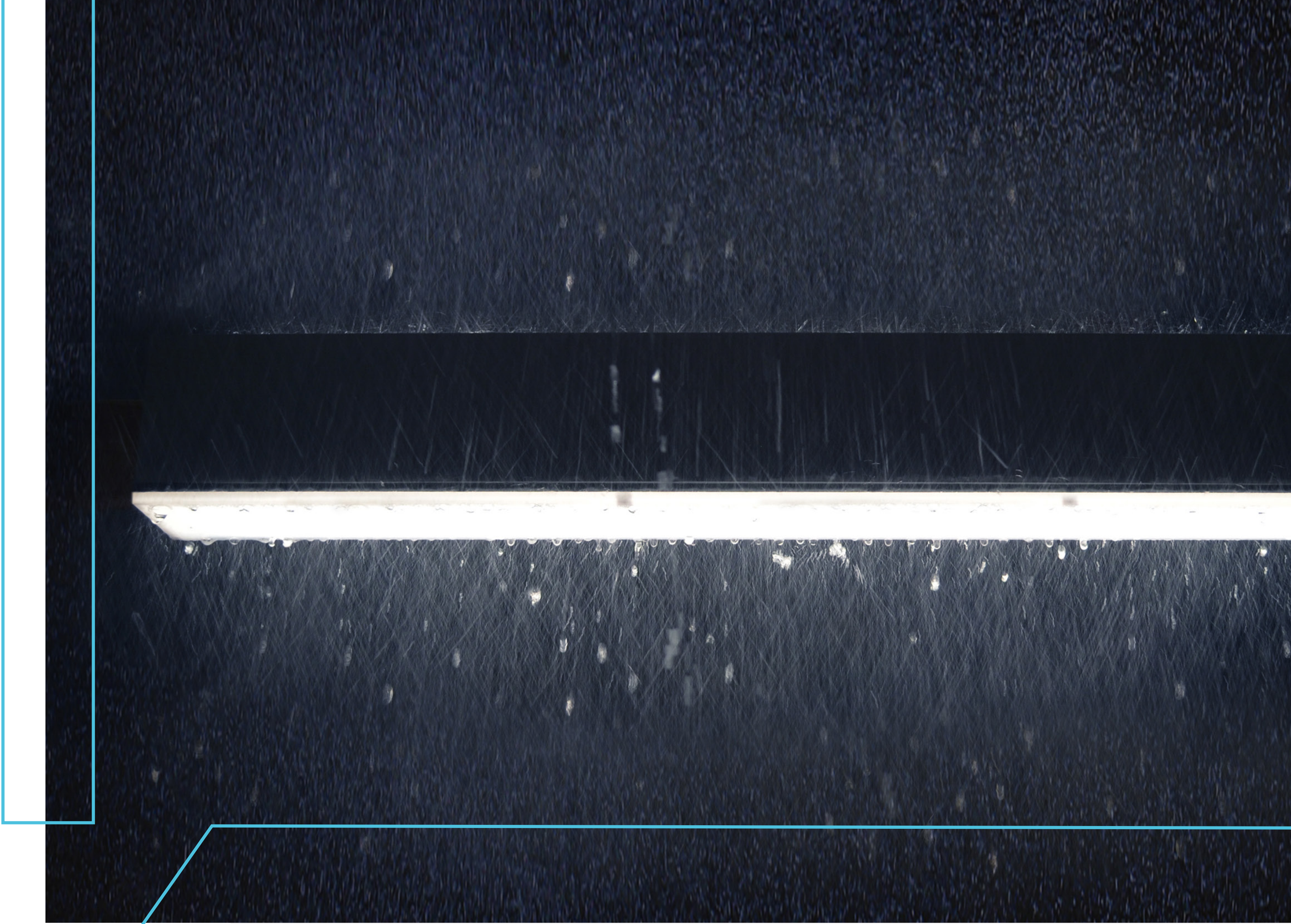
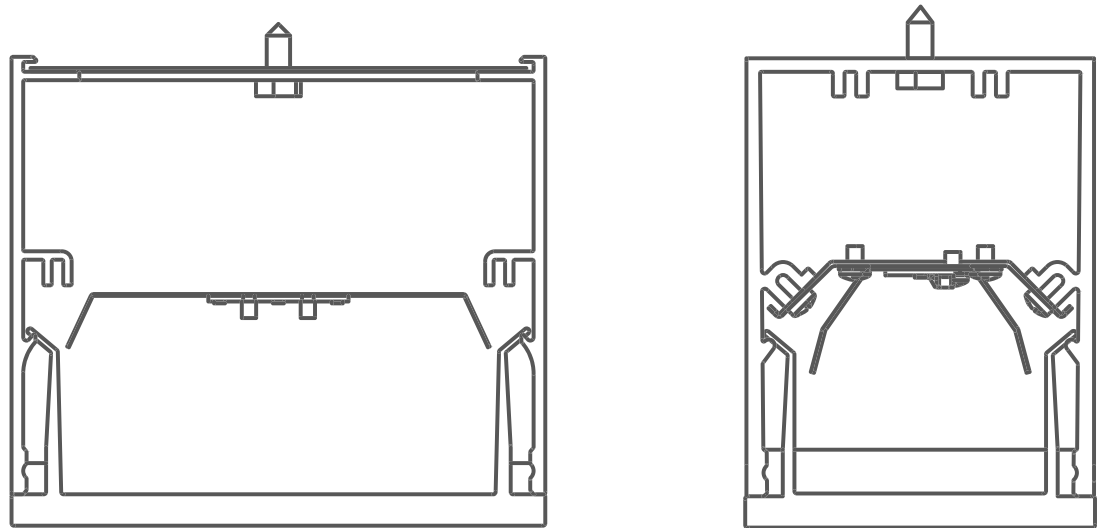

EDGE Wet 3"



497.5 Sq. Ft. Area
8' on Center
Satine Lens
3500K, Standard Output

Light Level (fc)	11.69 fc
Maximum	15.0 fc
Minimum	4.0 fc
Power Density (W/sq.ft.)	0.363

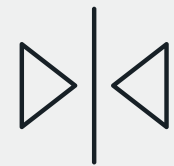

50/50/20 Reflectance
Light Loss Factor .9

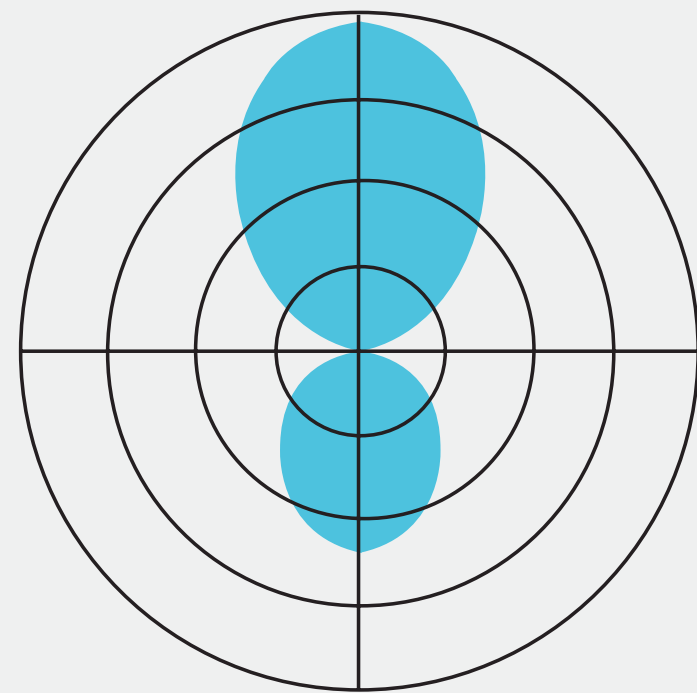

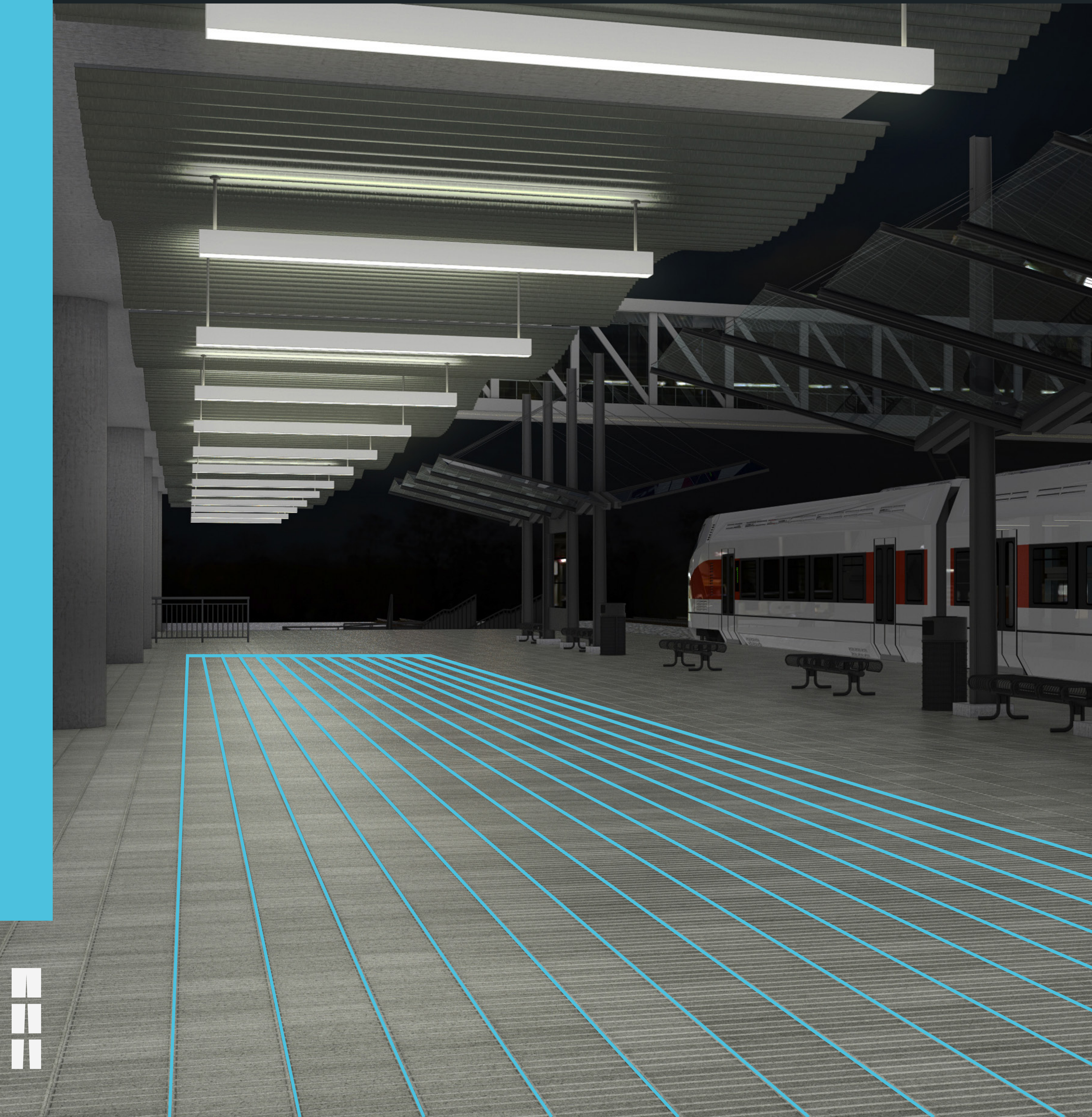

WITHSTAND THE ELEMENTS

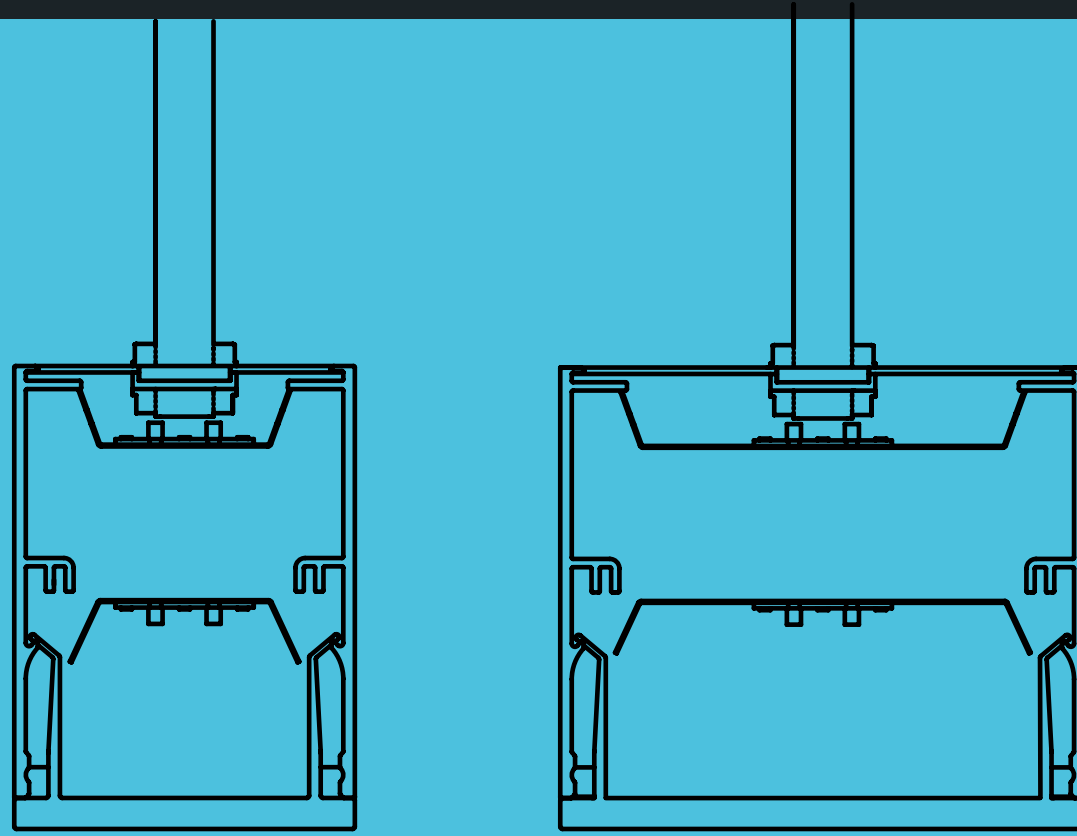



P I N N A C L E
ARCHITECTURAL LIGHTING®

3801 Havana St. Denver CO, 80239

Phone: 303.322.5570

www.pinnacle-ltg.com

March 2024

© 2024 Pinnacle Architectural
Lighting®

Specifications and dimensions subject to change without notice. Specification sheets and brochures that appear on pinnacle-ltg.com are the most recent version and supersede all other previously printed or electronic versions.