



Standard VERBENA Fixtures



CAC Cable Installation	2
Wall & Surface Mount Installation	3
Alternating Joint Installation	4
90° Corner Installation	5
120° Corner Installation	6
135° Corner Installation	7
“Y” Connector Installation	8
“T” Connector Installation	9
“X” Connector Installation	10
Remote Box Details	11
Lens Details	12



1 LAYOUT

Lay out mounting and J-Box locations.

Mount Spacing

Aircraft Cable Examples

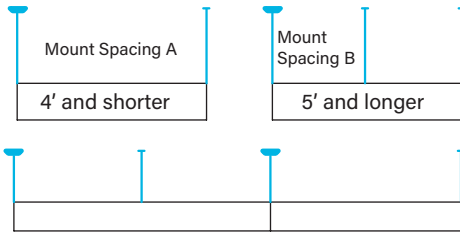

FIXTURE	A	B
2'	23-1/2"	N/A
3'	35-1/2"	N/A
4'	47-1/2"	N/A
5'	N/A	29-3/4"
6'	N/A	35-3/4"
7'	N/A	41-3/4"
8'	N/A	47-3/4"

*runs require all mounting points for first fixture, and all but first mounting point for all subsequent fixtures.

3 POWER SIDE MOUNT

Install Key Hole Bracket to J-Box. Run Conductive cable through Key Hole Bracket and make wiring connections inside of J-Box. Key Hole Bracket can be used for leveling by loosening/tightening screws. Use conductive Cable Collar for full adjustment. To adjust, loosen 10-32 pan head screws to allow the Collar to move on the Conductive Cable. Adjust to desired height and fully tighten the pan head screws against the Collar. Slide the canopy up to the ceiling plane.

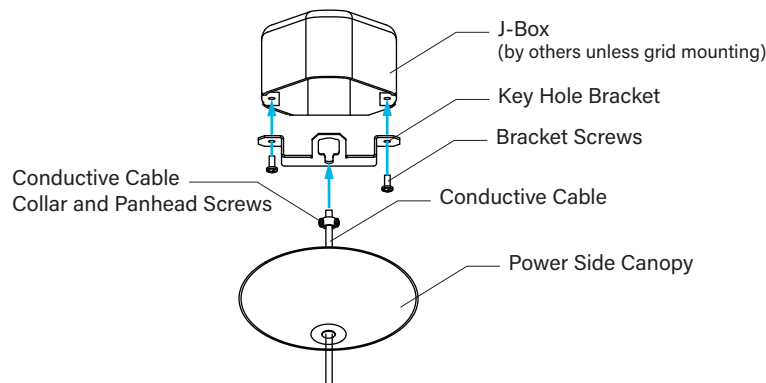

2 NON-POWER MOUNT

Install 1/4-20 stud (by others) or IDS Clip (by others) for non-power mounts (1/2" below ceiling plane). Thread AC cable through Coupler Base and run through side slot of coupler cap. Screw base and cap together. Secure canopy to stud or IDS clip using coupler. Adjust length of aircraft cable at ceiling coupler and trim excess.

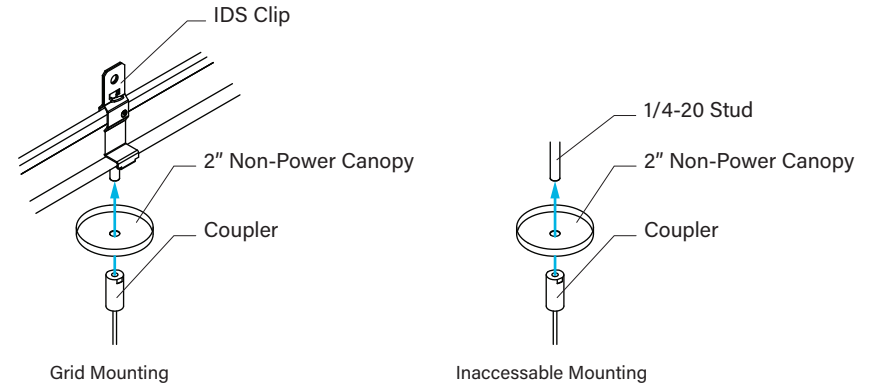

4 JOINING FIXTURES

Remove and discard cable retention plate. Slide fixture ends together and secure together using two supplied phillips head joining screws.

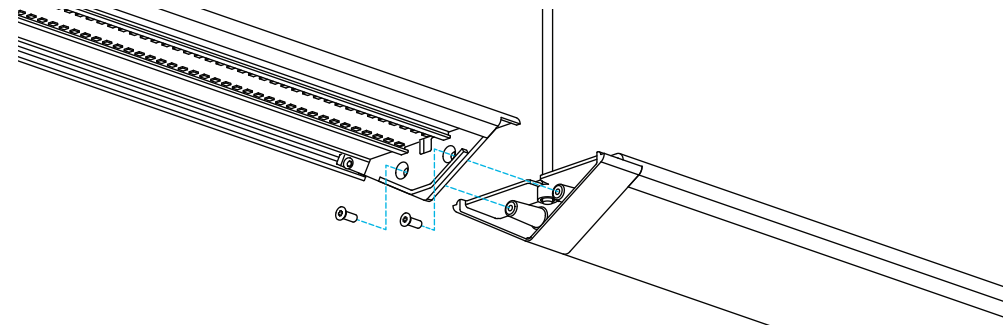



1 LAYOUT

Lay out junction boxes and fasten wall mounting brackets to the proper spacing for fixture type.

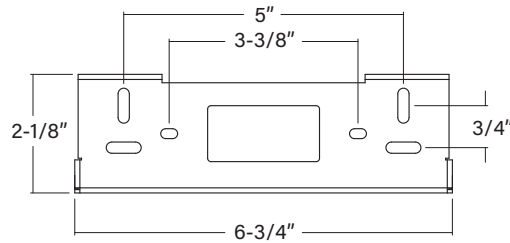
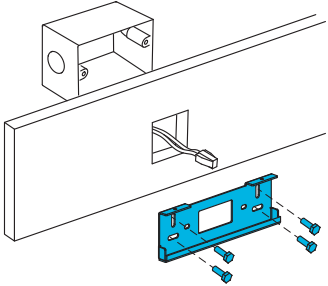

Wall Side Bracket

BEGINNING OF ROW OR INDEPENDENT FIXTURE (2 Mounting Brackets)

FIXTURE	DIM A
2'	12"
3'	24"
4'	36"
5'	48"
6'	60"
7'	72"
8'	84"

MIDDLE OR END OF ROW FIXTURES (1 Mounting Bracket)

FIXTURE	DIM B
2'	24"
3'	36"
4'	48"
5'	60"
6'	72"
7'	84"
8'	96"



2 POWER AND MOUNTING

Hang first fixture from mounting brackets for hands-free wiring (*only applicable when mounting on wall, when mounting to ceiling, 2 people are required to wire and mount fixture*). Connect fixture wiring to building power and recess wires into junction box. Rotate fixture upright and fasten with screws.

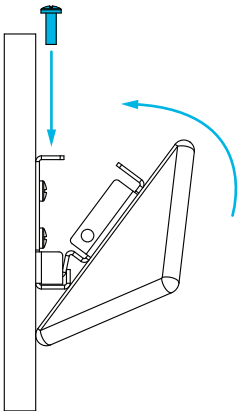

3 ADDITIONAL FIXTURES

If installing a run, hang additional fixture(s) on right end and support fixture on left. Connect wires and join to mounted fixture. When joining fixtures, slide fixture ends together and secure using two supplied joining screws (*see additional joining detail on page 2*). Fasten with screws.

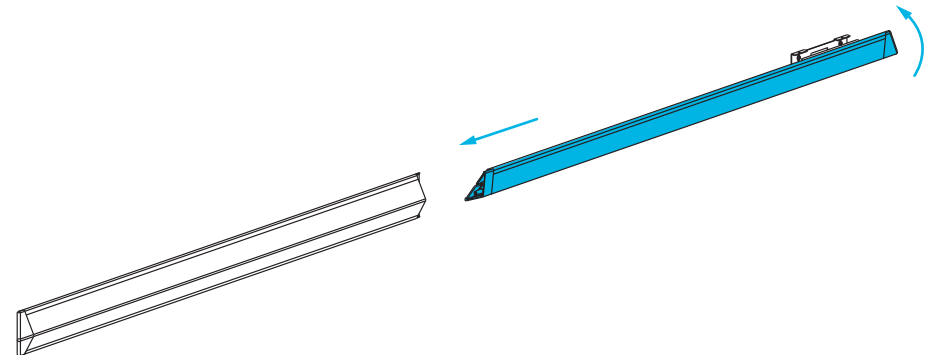



1 ALTERNATING JOINT

Lay out run and install mounting hardware. (*Note: alternating joint piece has one mount point.*) Attach joint to first fixture. Make electrical connection between first fixture and alternating joint. Attach joint to first fixture using two supplied joining screws. Attach joint cover plate and conductive cable. Hang joint using power side instructions on page 2. Join next fixture using two supplied joining screws. (*see additional joining detail on page 2*)

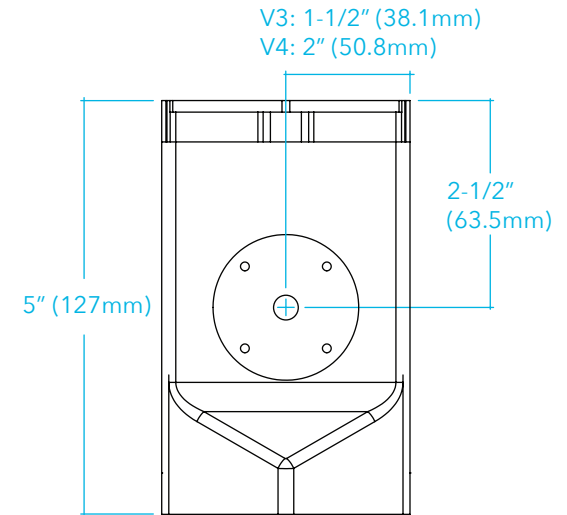
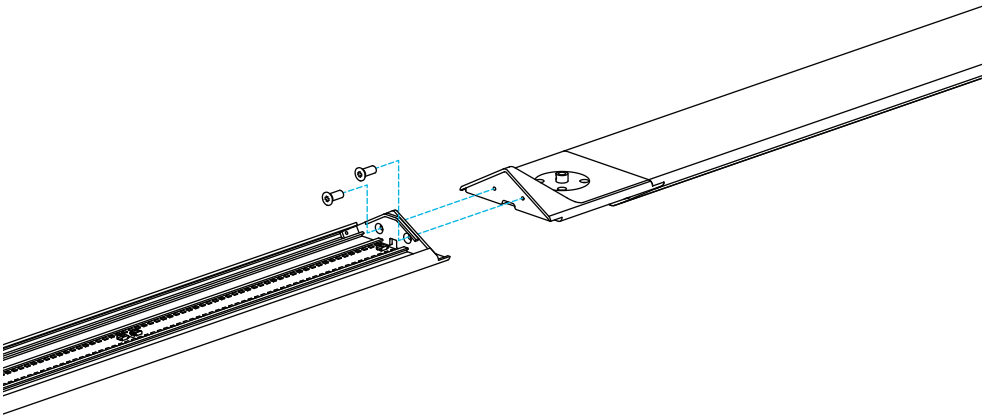



1 90° CONNECTOR

Lay out run and install mounting hardware. (*Note: corner has one mount point.*) Attach corner to first fixture. Make electrical connection between first fixture and corner. Attach to first fixture using two supplied joining screws. Attach corner cover plate and conductive cable. Hang using power side instructions on page 2. Join next fixture using two supplied joining screws. (*see additional joining detail on page 2*)

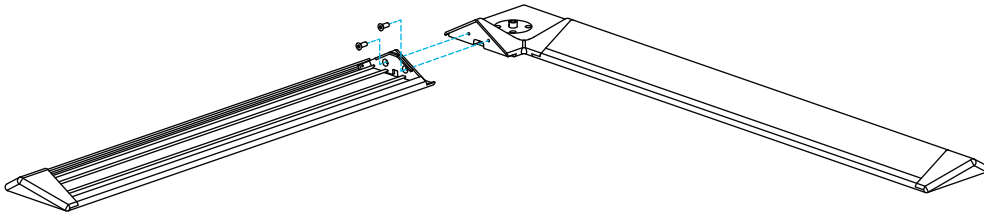

V3

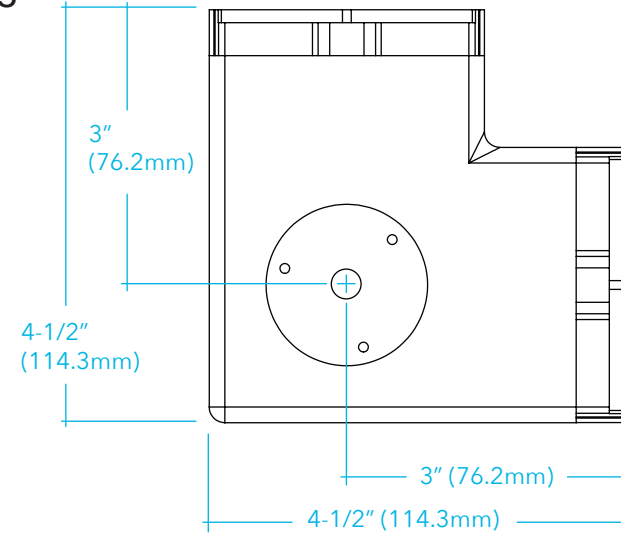

V4

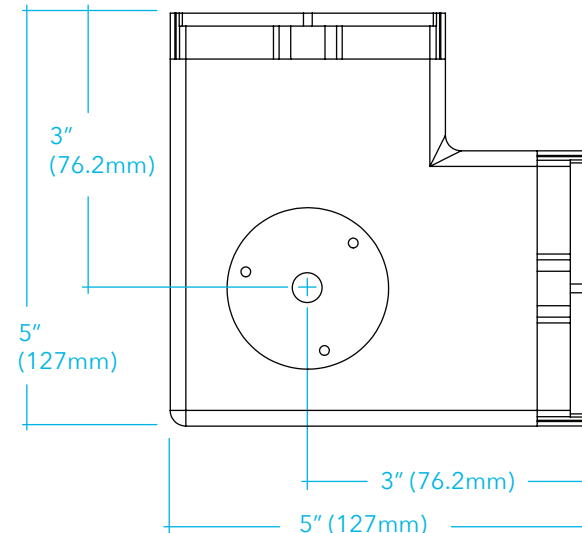



1 120° CONNECTOR

Lay out run and install mounting hardware. (*Note: corner has one mount point.*) Attach corner to first fixture. Make electrical connection between first fixture and corner. Attach to first fixture using two supplied joining screws. Attach corner cover plate and conductive cable. Hang using power side instructions on page 2. Join next fixture using two supplied joining screws. (*see additional joining detail on page 2*)

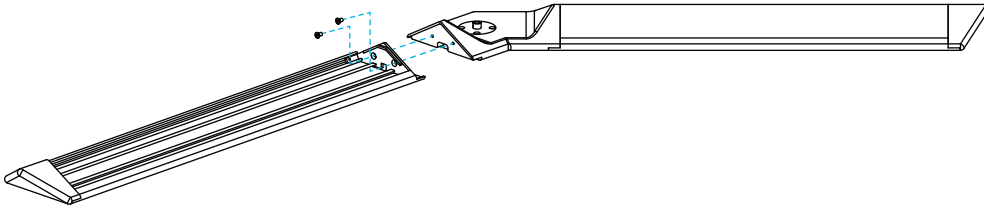

V3

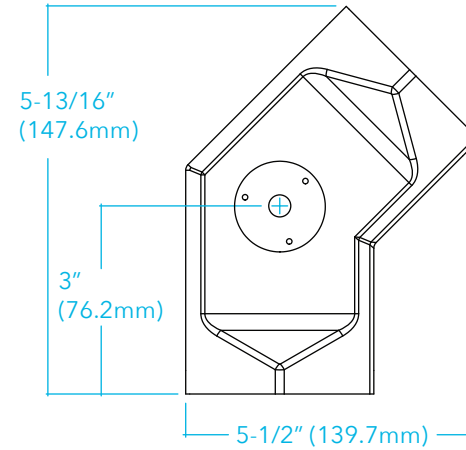

V4

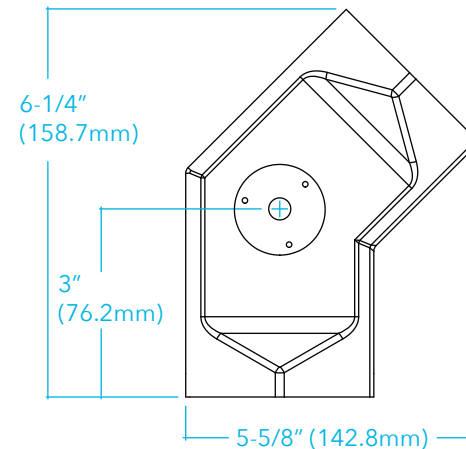



1 135° CONNECTOR

Lay out run and install mounting hardware. (*Note: corner has one mount point.*) Attach corner to first fixture. Make electrical connection between first fixture and corner. Attach to first fixture using two supplied joining screws. Attach corner cover plate and conductive cable. Hang using power side instructions on page 2. Join next fixture using two supplied joining screws. (*see additional joining detail on page 2*)

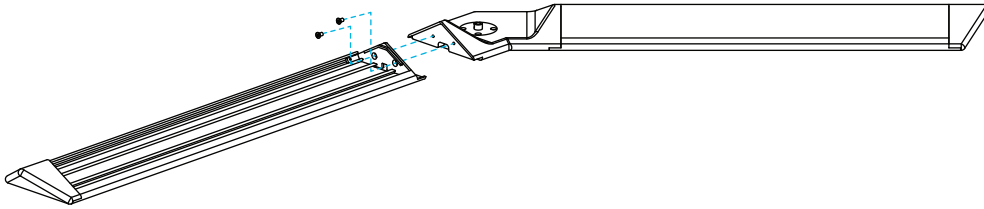

V3

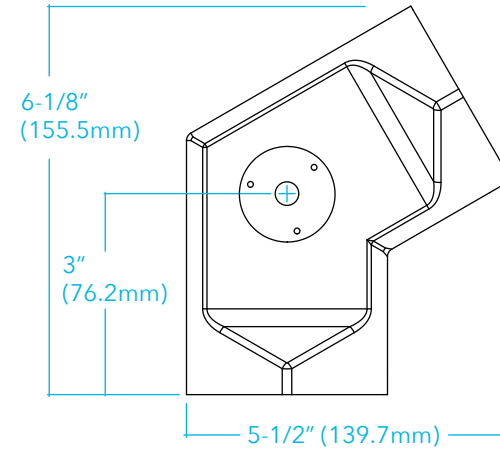

V4

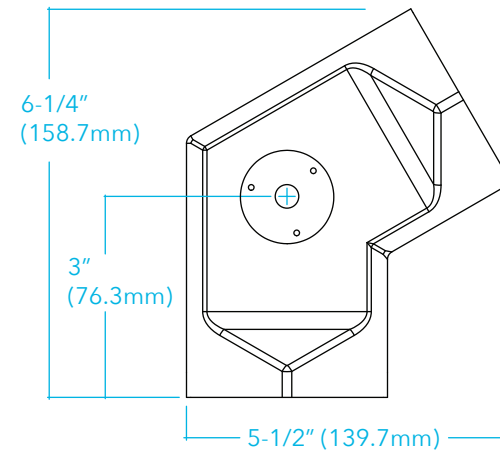



1 Y CONNECTOR

Lay out run and install mounting hardware. *(Note: corner has one mount point.)*
 Attach corner to first fixture. Make electrical connection between first fixture and corner. Attach to first fixture using two supplied joining screws. Attach corner cover plate and conductive cable. Hang using power side instructions on page 2. Join next fixture using two supplied joining screws. *(see additional joining detail on page 2)*

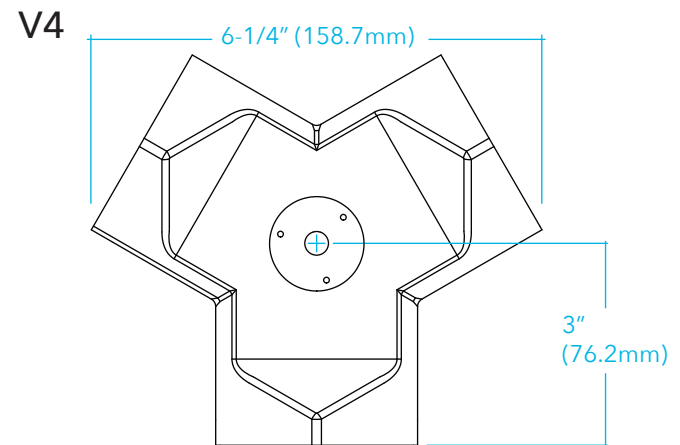
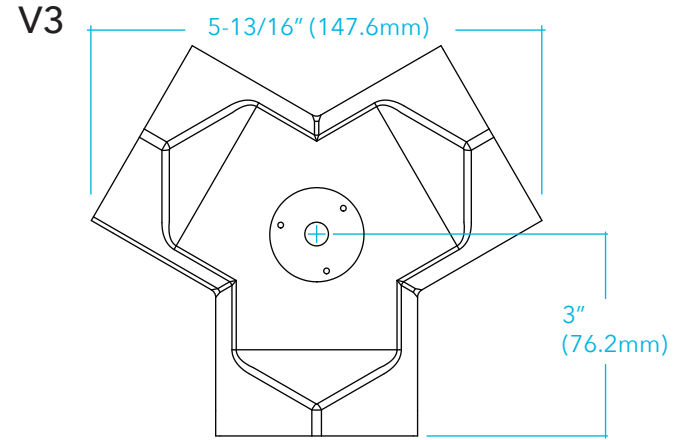
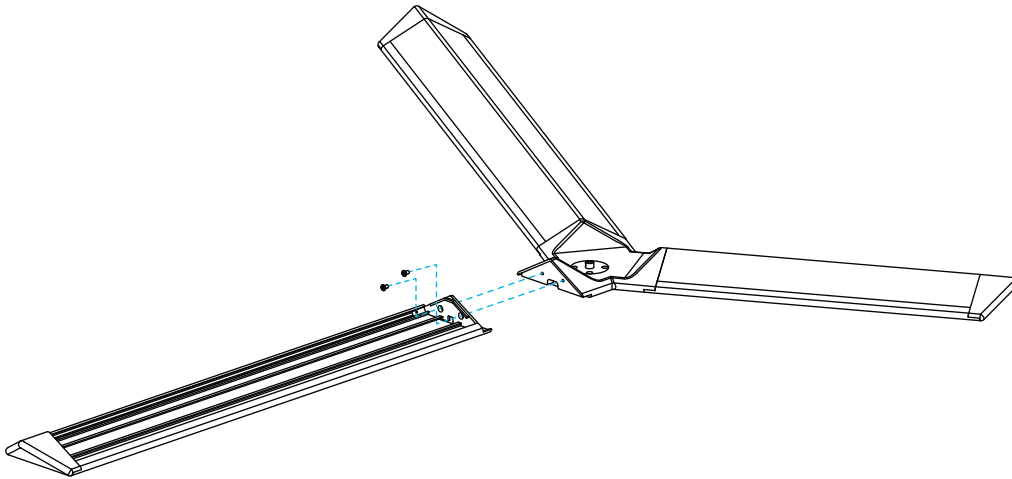



1 T CONNECTOR

Lay out run and install mounting hardware. (*Note: corner has one mount point.*) Attach corner to first fixture. Make electrical connection between first fixture and corner. Attach to first fixture using two supplied joining screws. Attach corner cover plate and conductive cable. Hang using power side instructions on page 2. Join next fixture using two supplied joining screws. (*see additional joining detail on page 2*)

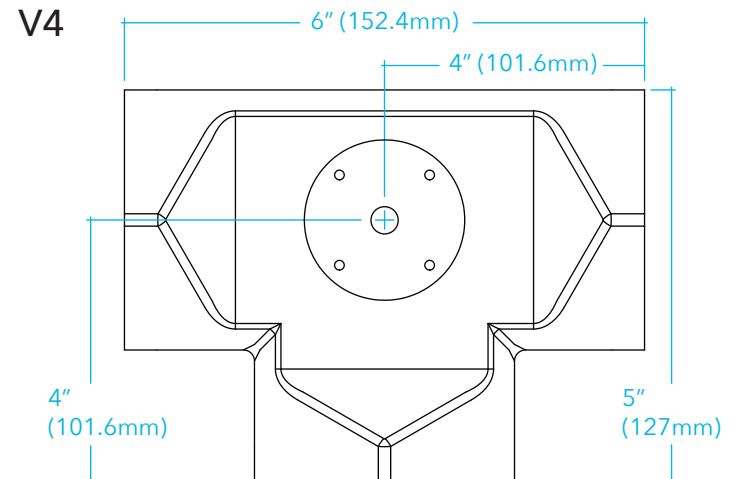
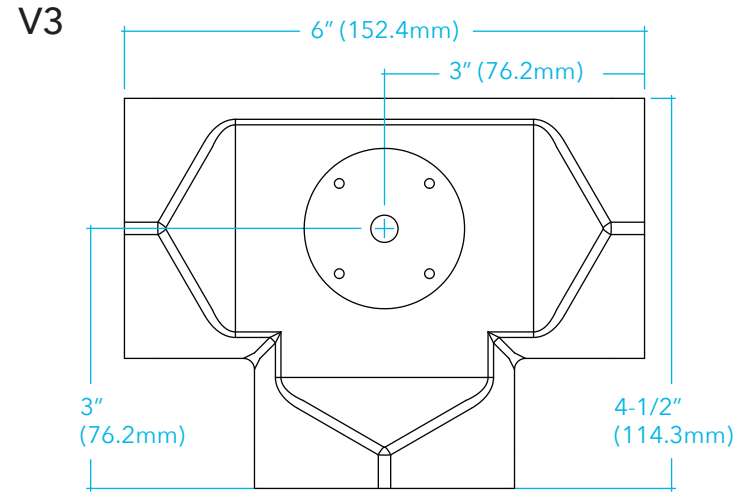
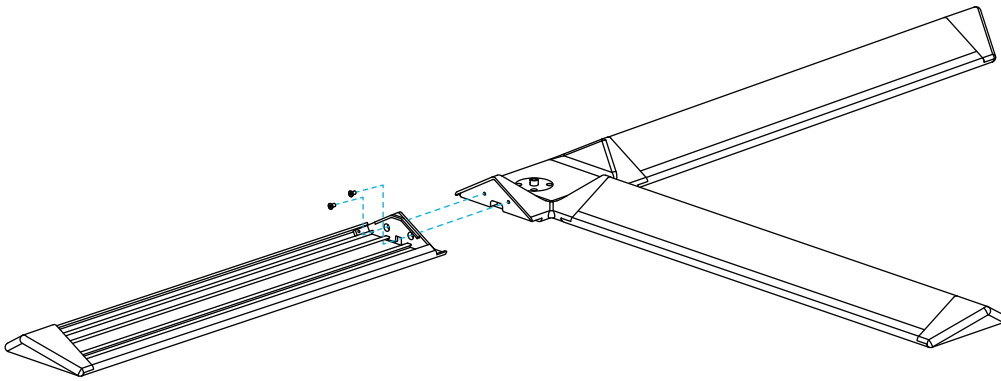



1 X CONNECTOR

Lay out run and install mounting hardware. (*Note: corner has one mount point.*) Attach corner to first fixture. Make electrical connection between first fixture and corner. Attach to first fixture using two supplied joining screws. Attach corner cover plate and conductive cable. Hang using power side instructions on page 2. Join next fixture using two supplied joining screws. (*see additional joining detail on page 2*)

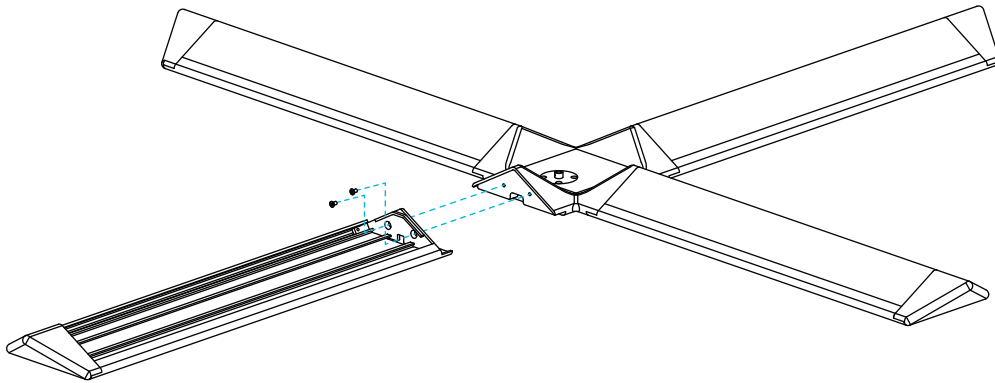

V3

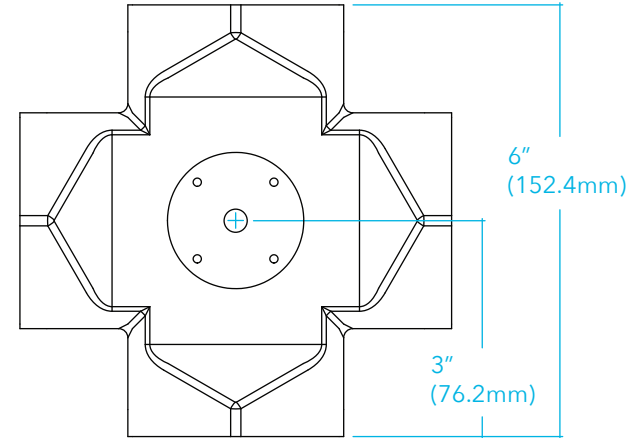

V4

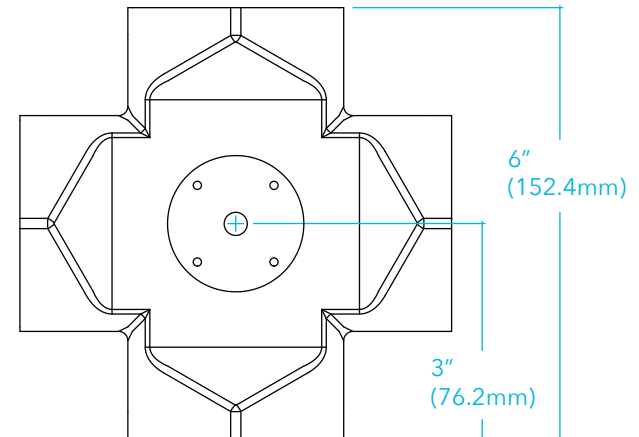



1 SLIM REMOTE BOX TO GRID

Install slim remote driver box onto grid using pre-installed grid clips. To open remote box, remove two #6-32x1/4 screws on top of box. Use 1/2" trade knockout on high voltage side to connect to building power. Use 2' long Flexwhip to bring power to J-Box.

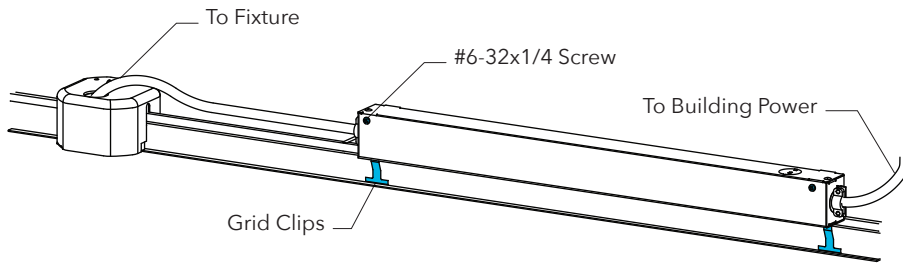

2 SLIM REMOTE BOX TO SURFACE

Remove two grid brackets on back of remote driver box. Open remote driver box by removing two #6-32x1/4 screws on top of box. Install remote driver box to surface using 1/4" mounting hardware (by others). Connect to building power using 1/2" trade knockout on high voltage side. Then connect to J-Box using 2' long Flexwhip.

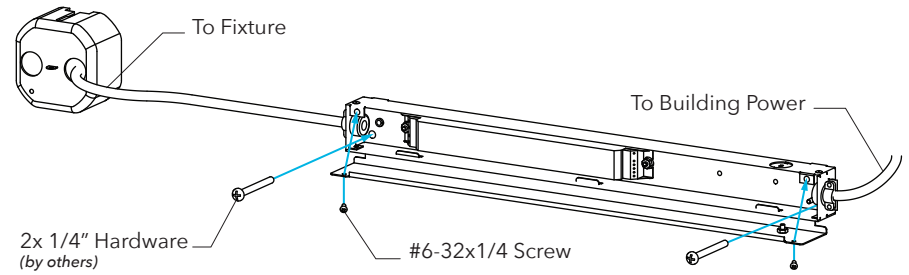

1 STANDARD REMOTE BOX TO GRID

Place Remote Driver Box onto grid and bend grid tabs over securing with a #8 Sheet Metal Screw. To open remote box, remove three #8-32x1/4 screws on top of box. Use 1/2" trade knock out on high voltage side to connect to building power. Use 2' long Flexwhip to bring power to J-Box.

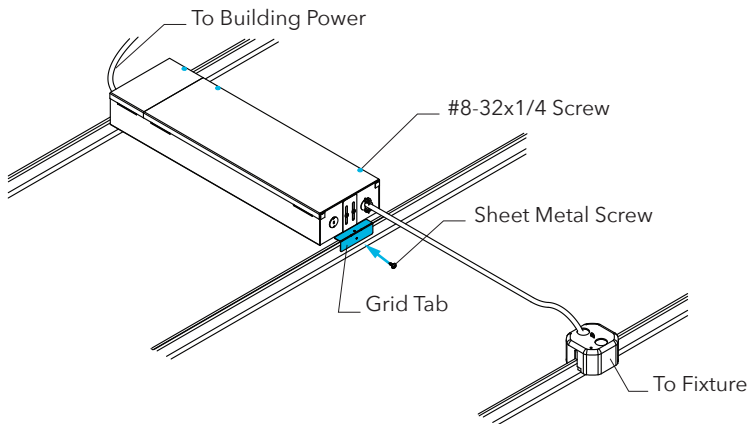

2 STANDARD REMOTE BOX TO SURFACE

Remove Grid Brackets on sides of Remote Driver Box. Open Remote Driver Box by removing three #8-32x1/4 screws on top of box. Install Remote Driver box to surface using 1/4" Mounting Hardware. Use 1/2" Trade Knock out on high voltage side to connect to building power. Use 2' long Flexwhip to bring power to J-Box.

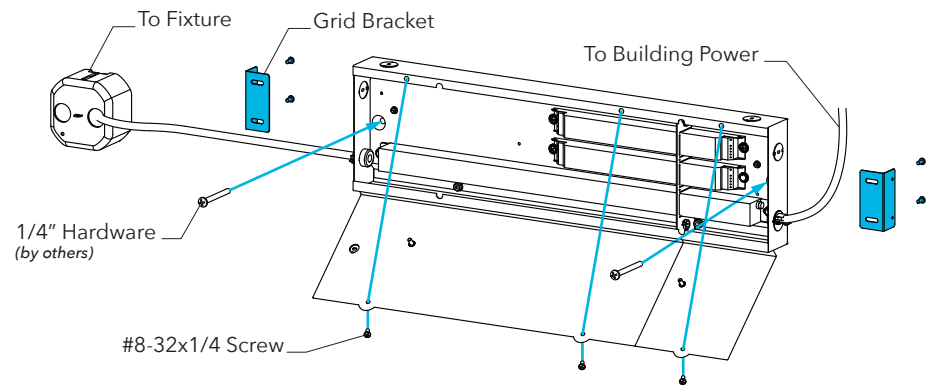



1 LENS REMOVAL

Squeeze lens near end cap and pry away from fixture using a putty knife. Pull down gently while sliding putty knife along the length of lens.

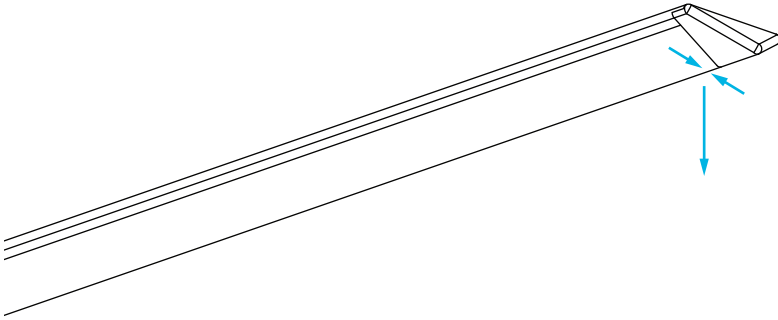

2 LENS INSTALLATION

Beginning at one end, squeeze lens legs together and slide into fixture. Slowly insert rest of lens down the length of the fixture, snapping into place.

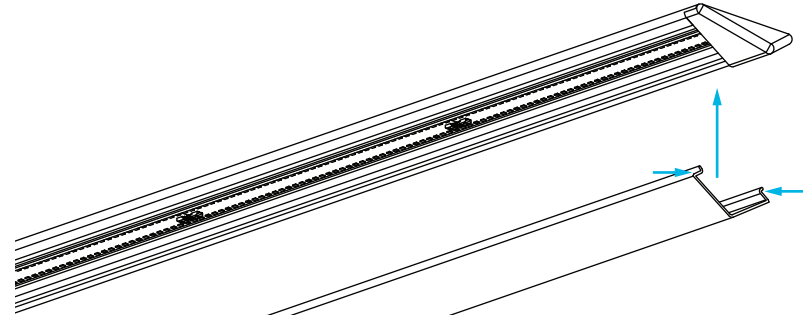

DISCLAIMERS

*This product must be installed in accordance with applicable installation and electrical codes by a professional familiar with the construction and operation of the product.
Minimum 90° C supply conductor.
All electrical connections must be performed by a certified electrician to applicable local and national electrical codes.*

*Damaged components must never be used.
Contact Pinnacle prior to making any fixture alterations.
Contact Pinnacle with any installation questions or field issues.*