



# EDGE Evolution EX12

## INSTALLATION INSTRUCTIONS

### *Full Size Remote Box*

AC to Junction Box Installation.....	2-4
Surface Mount.....	5-7
Wall Mount.....	8-10
Remote Box Details.....	11-13

### *Inaccessible Ceilings Canopy Remote Box*

New Construction Installation.....	14-17
Retrofit Installation.....	18-21
Remote Box to Fixture Instructions.....	22-23

Lens Detail.....	24-25
------------------	-------



# EDGE Evolution EX12

FULL SIZE REMOTE BOX  
AC TO JUNCTION BOX  
INSTALLATION

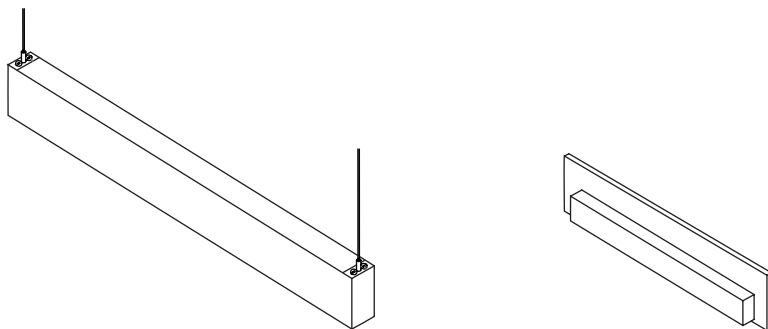

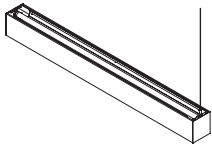

# EDGE EVOLUTION EX12

# LED AC - to - JB Mount

Return to Main Menu

## Step 1: Power at Ceiling

1. Layout mounting / junction box locations. Begin row with fixture label at first mounting point.
2. Install crossbar to 4"-octagonal junction box.
3. Run SJT cord through canopy and into junction box, secure with strain relief.
4. Make all necessary wiring connections.
5. Feed aircraft cable through coupler, secure canopy to crossbar bolt using coupler.

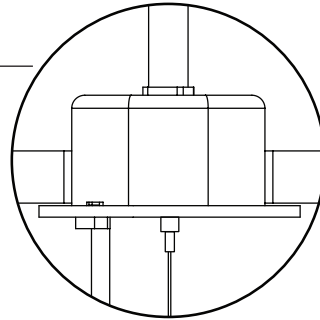

## Step 2: Non Power Mount

1. Install 1/4-20 stud or IDS Clip for non-power mounts (1/2" below ceiling plane).
2. Feed aircraft cable through coupler.
3. Secure canopy to stud or IDS Clip using coupler.

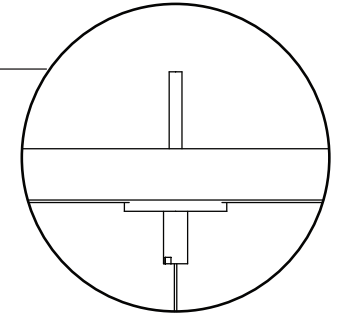

\* Stud sits 1/2" Below Ceiling Plane

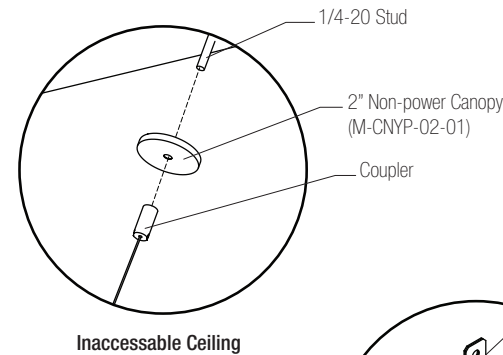
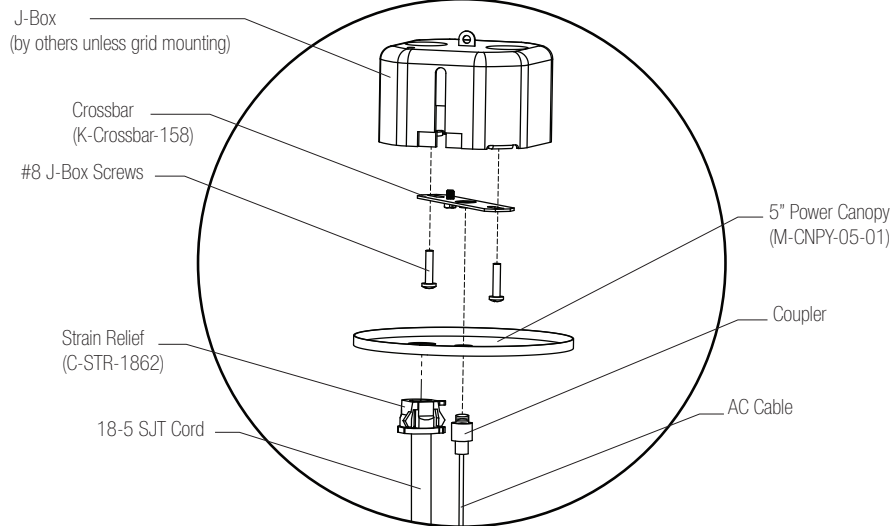

Inaccessible Ceiling

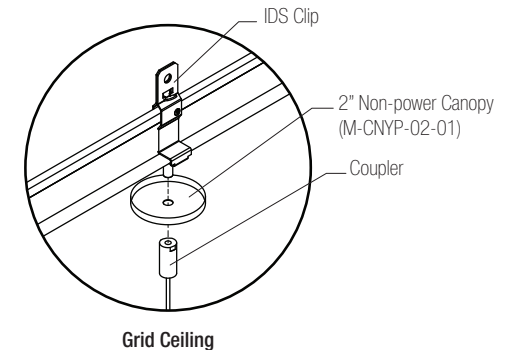

Grid Ceiling

AC cables with damage, bends, kinks, fraying, or knots must be discarded and replaced with new components. Never install a fixture where the AC cable is more than 5 degrees from perpendicular to the fixture. Fixtures are never to be raised by the cables (instead, lift the fixture up and adjust the cable position). Overtightening of hardware on grippers can damage AC cables. Never exert force down onto the top of the fixture once it is hanging by safety cables. Never cut safety cables prior to installation. The first zip tie on the SJT and AC cables below the ceiling/canopy must be no closer than 12" from the ceiling/canopy.



1. This product must be installed in accordance with applicable installation and electrical codes by a professional familiar with the construction and operation of the product.
2. Minimum 90°C supply conductors
3. All electrical connections must be performed by a certified electrician to applicable local and national electrical codes.

4. Fixtures must be mounted directly to structure.
5. The holding strength of AC cables cannot be guaranteed if the cables are damaged in any way.
6. All of Pinnacle's packaging is recyclable with the exception of the straps on the pallets. Please reach out to the factory if you need assistance in recycling any packaging components.

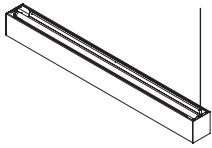

# EDGE EVOLUTION EX12

# LED AC - to - JB Mount

Return to Main Menu

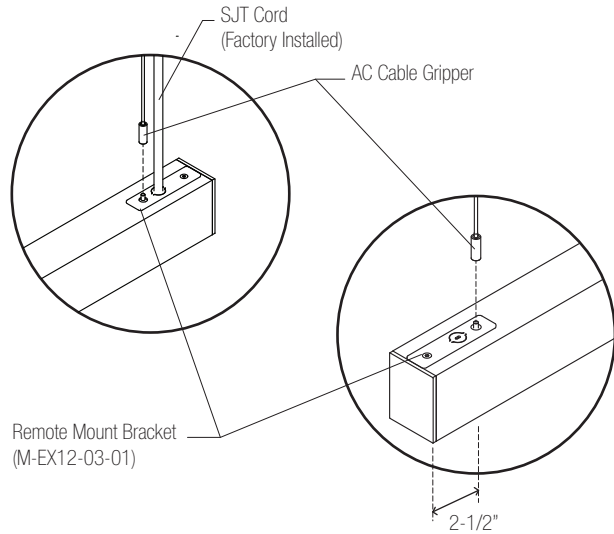

### Step 3: AC Mounting

#### Power Side

1. Attach AC Cable Gripper to stud on top of housing.

#### Non Power Side

1. Attach AC Cable Gripper to Stud on top of housing.
2. Once both sides are hung level fixture.

### Mount Spacing

Aircraft Cable - Example Rows

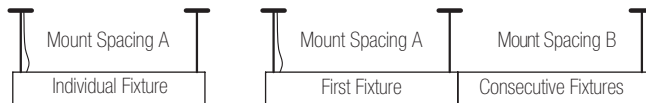

Length	A	B
2'	19"	24"
3'	31"	36"
4'	43"	48"
5'	55"	60"
6'	67"	72"
7'	79"	84"
8'	91"	96"

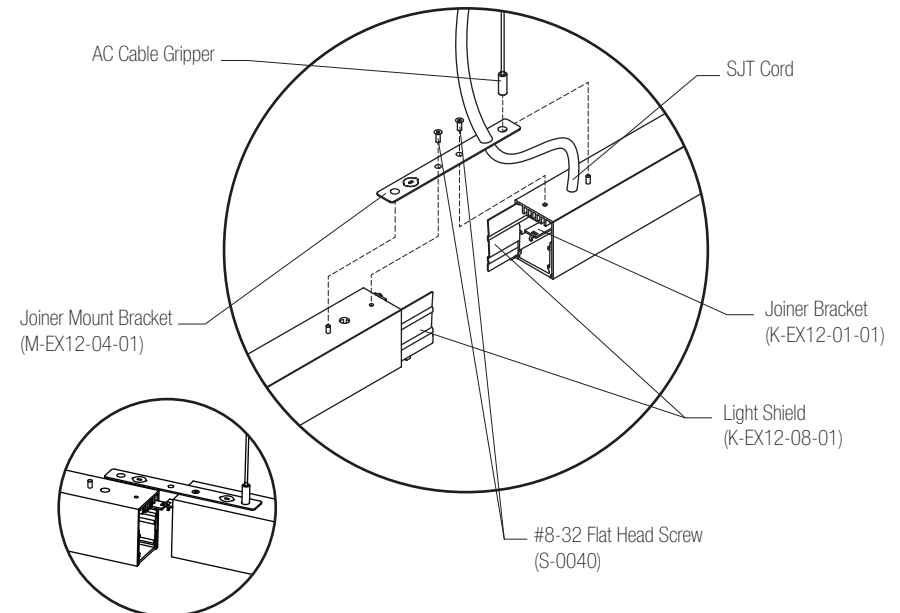

\* Hands Free Wiring Position \*

### Step 4: Joining Fixtures

1. If SJT Cable is present, feed SJT Cable through knockout in Joiner Bracket.
2. Attach Joiner Mount Bracket to incoming fixture using provided #6-32 Flat Head Screw.
3. Hang fixture via AC Cable Gripper and stud protruding from fixture through Joiner Mount Bracket.
4. Hook fixtures together into the Hands Free Wiring Position via joiner bracket.
5. Make all necessary wiring connections between fixtures.
6. Unhook fixtures and slide together using Light Shields for alignment.
7. Secure subsequent fixture and Joiner Mount Bracket with #6-32 Flat Head Screw.
8. Hang fixture via AC Cable Gripper and stud protruding from fixture through Joiner Mount Bracket



1. This product must be installed in accordance with applicable installation and electrical codes by a professional familiar with the construction and operation of the product.  
 2. Minimum 90°C supply conductors  
 3. All electrical connections must be performed by a certified electrician to applicable local and national electrical codes.

4. Fixtures must be mounted directly to structure.  
 5. The holding strength of AC cables cannot be guaranteed if the cables are damaged in any way.  
 6. All of Pinnacle's packaging is recyclable with the exception of the straps on the pallets. Please reach out to the factory if you need assistance in recycling any packaging components.



# EDGE Evolution EX12

FULL SIZE REMOTE BOX  
SURFACE MOUNT  
INSTALLATION

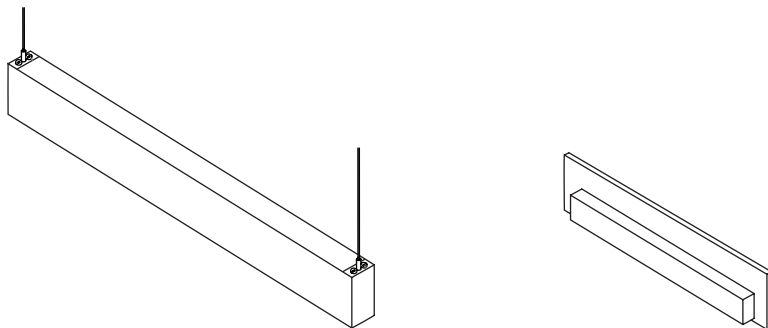

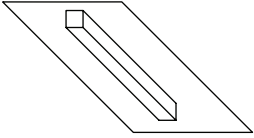

# EDGE EVOLUTION EX12 Surface Mount Instructions

Return to Main Menu

## Step 1: Fixture Prep

1. Ensure proper support behind the fixture.  
*(see chart on page 2 for mounting locations)*
2. Remove lenses.
3. Remove Matte Black #8-32 screws to remove the reflector assembly.

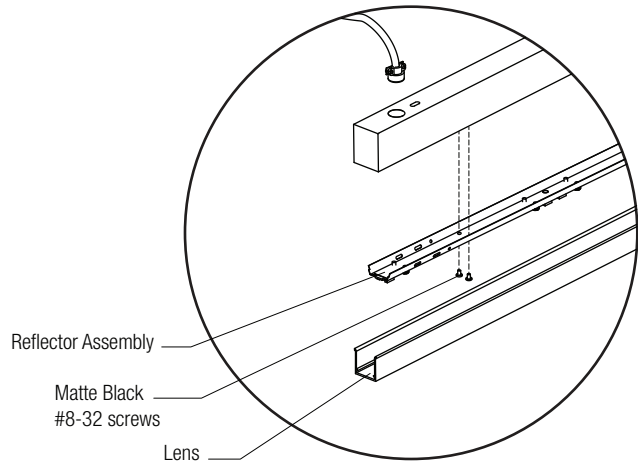

## Step 2: Wiring Power

1. Feed flexwhip into electrical access and secure using strain relief.
2. Make all necessary wiring connections.  
*(Note: power drop required every 8ft.)*

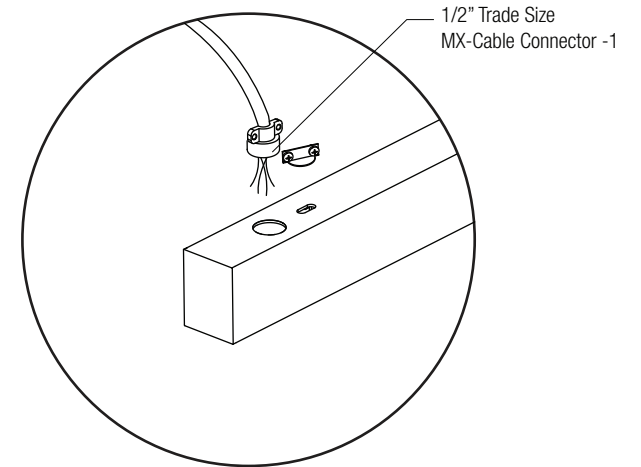

1. This product must be installed in accordance with applicable installation and electrical codes by a professional familiar with the construction and operation of the product.
2. Minimum 90°C supply conductors
3. All electrical connections must be performed by a certified electrician to applicable local and national electrical codes.

4. Fixtures must be mounted directly to structure.
5. The holding strength of AC cables cannot be guaranteed if the cables are damaged in any way.
6. All of Pinnacle's packaging is recyclable with the exception of the straps on the pallets. Please reach out to the factory if you need assistance in recycling any packaging components.

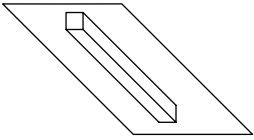

# EDGE EVOLUTION EX12 Surface Mount Instructions

Return to Main Menu

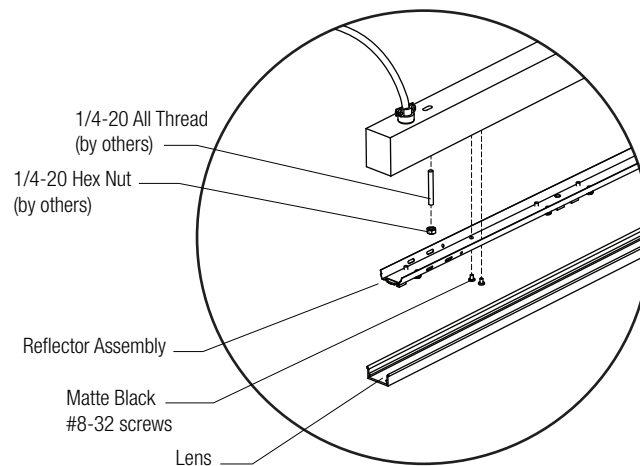
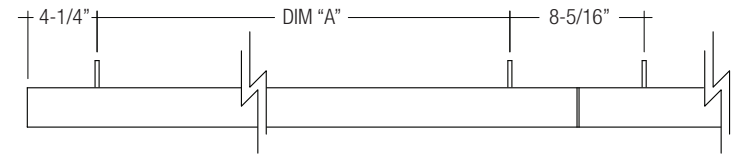
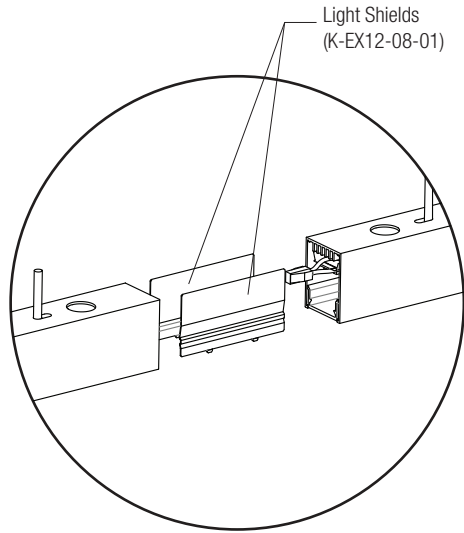

Fixture Length	DIM "A"
2'	15-11/16"
3'	27-11/16"
4'	39-11/16"
5'	51-11/16"
6'	63-11/16"
7'	75-11/16"
8'	87-11/16"

### Step 3: Joining Fixtures

1. If joining fixtures, fixtures are through wired.
2. Make all necessary wiring connections between fixtures.
3. Recess wires into fixture.
4. Slide fixtures together using Light Shields to align fixtures.

### Step 4: Mounting and Finishing

1. When mounting fixtures, each fixture has two mounting points.
2. With reflector assembly removed, mount the fixture to the surface through the housing using 1/4-20 hardware (by others).
3. Once mounted, re-install all Reflectors and Lenses.



1. This product must be installed in accordance with applicable installation and electrical codes by a professional familiar with the construction and operation of the product.  
 2. Minimum 90°C supply conductors  
 3. All electrical connections must be performed by a certified electrician in applicable local and national electrical codes.

4. Fixtures must be mounted directly to structure.  
 5. The holding strength of AC cables cannot be guaranteed if the cables are damaged in any way.  
 6. All of Pinnacle's packaging is recyclable with the exception of the straps on the pallets. Please reach out to the factory if you need assistance in recycling any packaging components.



# EDGE Evolution EX12

FULL SIZE REMOTE BOX  
WALL MOUNT  
INSTALLATION

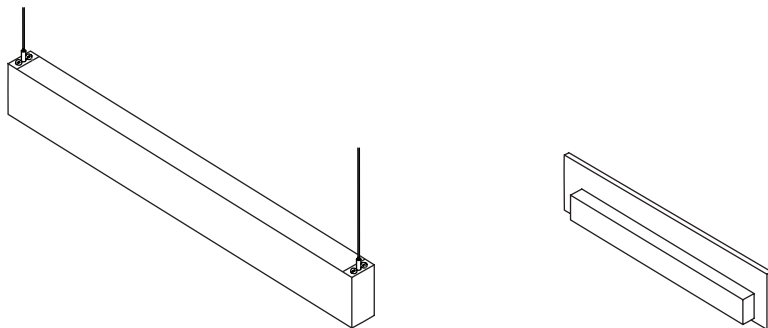



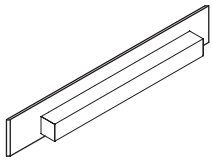

### Step 1: Wall Bracket

1. Attach wall side bracket to structure via mounting hardware (by others).
2. If power side, mount bracket in line with 2x4 junction box (by others).
3. Bring power in through junction box.
4. Follow mount spacing on page 2 for additional mounting points.

*(Note: See page 2 for additional mount dimensions)*

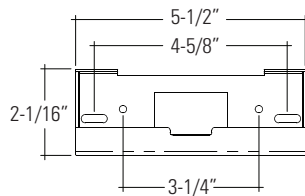
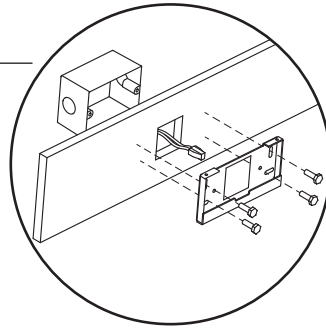

Wall Side Bracket

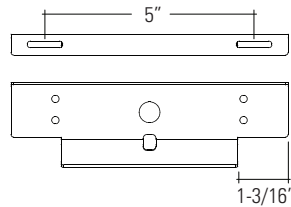

Fixture Side Bracket

### Step 2: Power Mount

1. To power fixture, attach building power to fixture power wires using push nuts.
2. Push connections into junction box.
3. Attach fixture to wall bracket as shown.
4. Make necessary adjustments laterally prior to tightening wall mount screw.

*(Note: See page 2 for additional mount dimensions)*

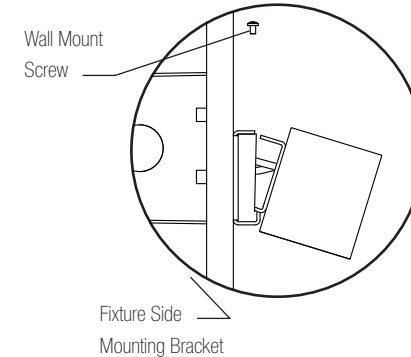
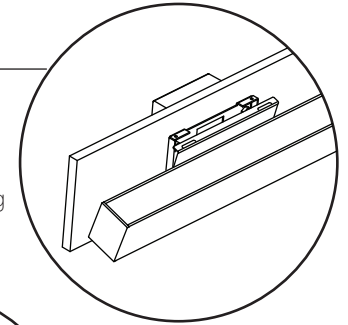

### Step 3: Joining Fixtures

1. Remove all lenses.
2. Mount next fixture in row.
3. Make necessary wiring connections between fixtures.
4. Slide the fixtures together using the Light Shields as guides.
5. Place Joiner Tie into the slots of the Joiner Brackets on both fixtures.
6. Secure Joiner Tie using (2) #8-32 Screws.
7. Tighten Wall Bracket screws.
8. Replace Lenses.
9. Repeat for all subsequent fixtures.

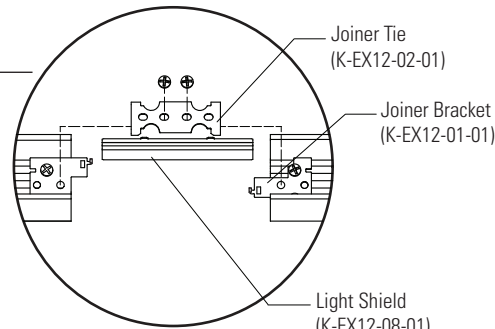

1. This product must be installed in accordance with applicable installation and electrical codes by a professional familiar with the construction and operation of the product.
2. Minimum 90°C supply conductors
3. All electrical connections must be performed by a certified electrician to applicable local and national electrical codes.

4. Fixtures must be mounted directly to structure.
5. The holding strength of AC cables cannot be guaranteed if the cables are damaged in any way.
6. All of Pinnacle's packaging is recyclable with the exception of the straps on the pallets. Please reach out to the factory if you need assistance in recycling any packaging components.

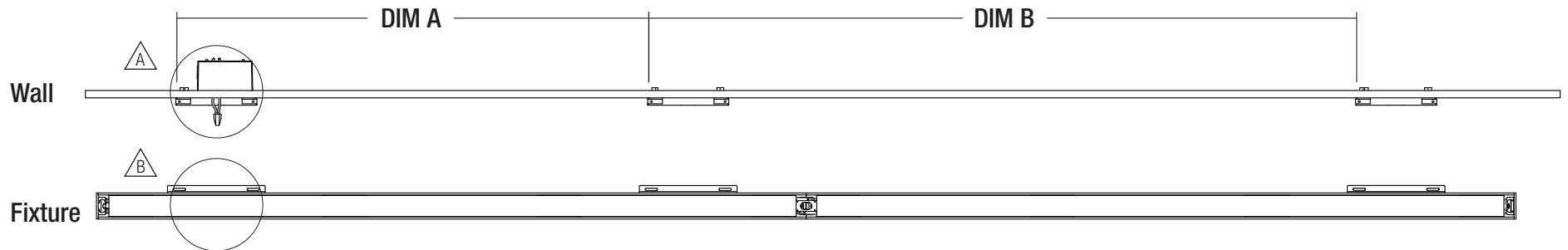
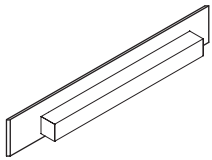

\* Note: Power typically \*  
on left side of fixture.

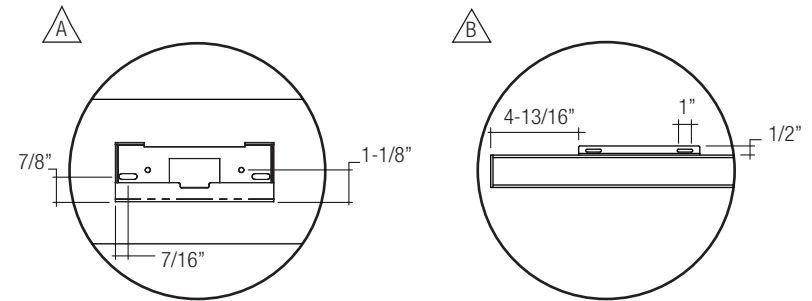

**Beginning of Row or  
Independent Fixture**  
*(2 mounting brackets)*

Nominal Fixture Length	Dim "A"
2'	8"
3'	20"
4'	32"
5'	44"
6'	56"
7'	68"
8'	80"

**Intermediate or End  
of Row Fixture**  
*(1 mounting bracket)*

Nominal Fixture Length	Dim "B"
2'	24"
3'	36"
4'	48"
5'	60"
6'	72"
7'	84"
8'	96"



1. This product must be installed in accordance with applicable installation and electrical codes by a professional familiar with the construction and operation of the product.
2. Minimum 90°C supply conductors
3. All electrical connections must be performed by a certified electrician to applicable local and national electrical codes.

4. Fixtures must be mounted directly to structure.
5. The holding strength of AC cables cannot be guaranteed if the cables are damaged in any way.
6. All of Pinnacle's packaging is recyclable with the exception of the straps on the pallets. Please reach out to the factory if you need assistance in recycling any packaging components.



# EDGE Evolution EX12

REMOTE BOX  
DETAILS

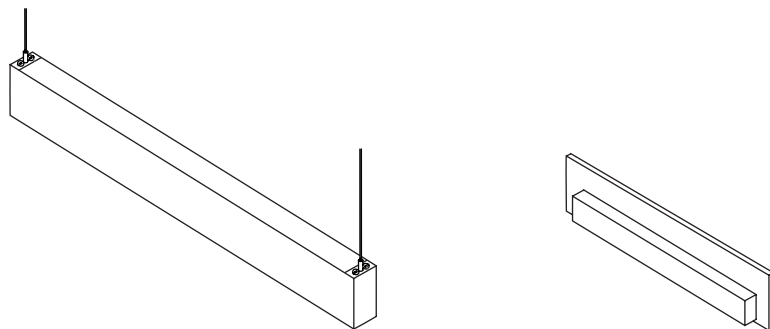

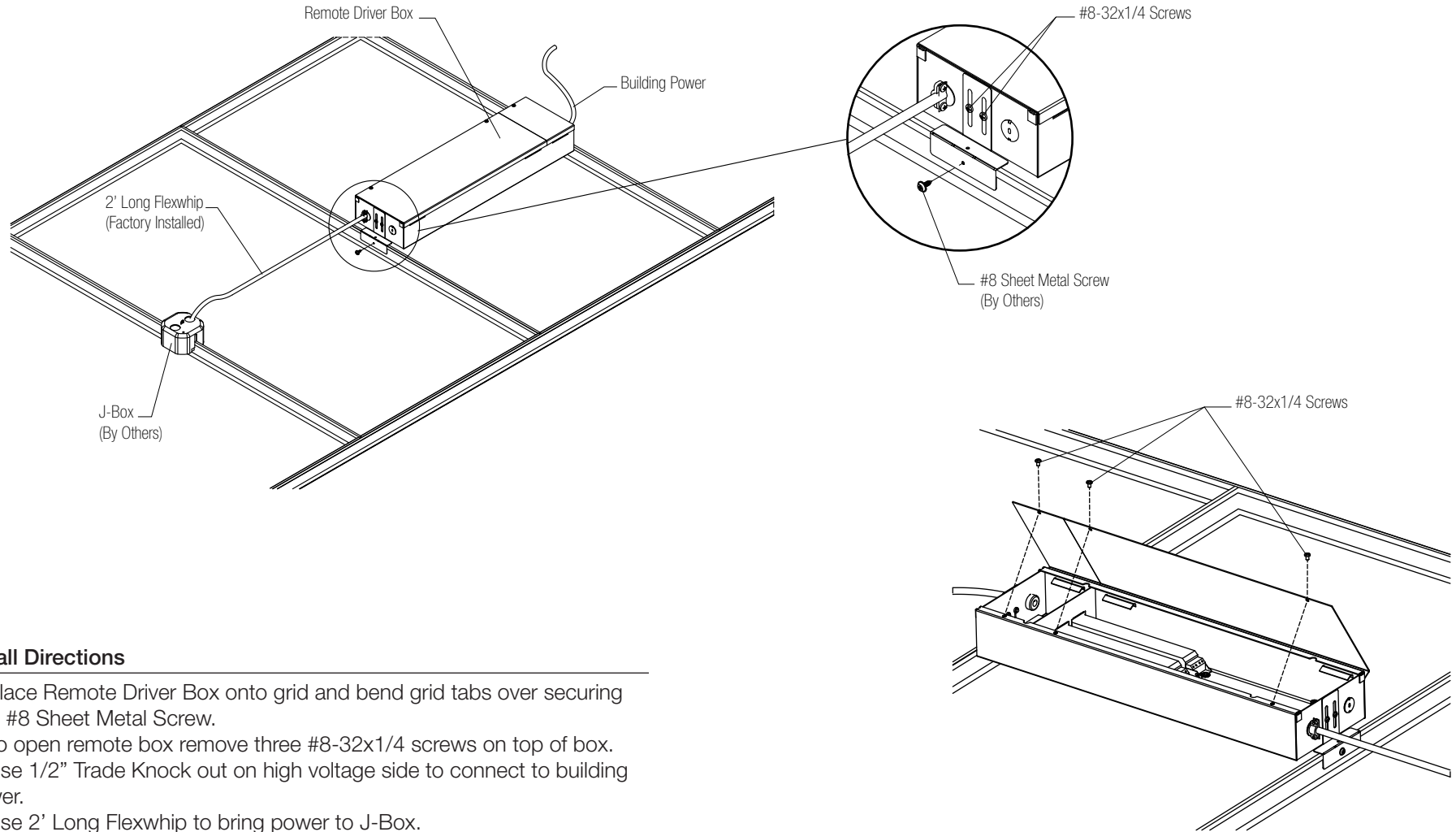
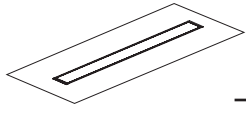

**Install Directions**

1. Place Remote Driver Box onto grid and bend grid tabs over securing with #8 Sheet Metal Screw.
2. To open remote box remove three #8-32x1/4 screws on top of box.
3. Use 1/2" Trade Knock out on high voltage side to connect to building power.
4. Use 2' Long Flexwhip to bring power to J-Box.



1. This product must be installed in accordance with applicable installation and electrical codes by a professional familiar with the construction and operation of the product.
2. Minimum 90°C supply conductors
3. All electrical connections must be performed by a certified electrician to applicable local and national electrical codes.

4. Fixtures must be mounted directly to structure.
5. The holding strength of AC cables cannot be guaranteed if the cables are damaged in any way.
6. All of Pinnacle's packaging is recyclable with the exception of the straps on the pallets. Please reach out to the factory if you need assistance in recycling any packaging components.

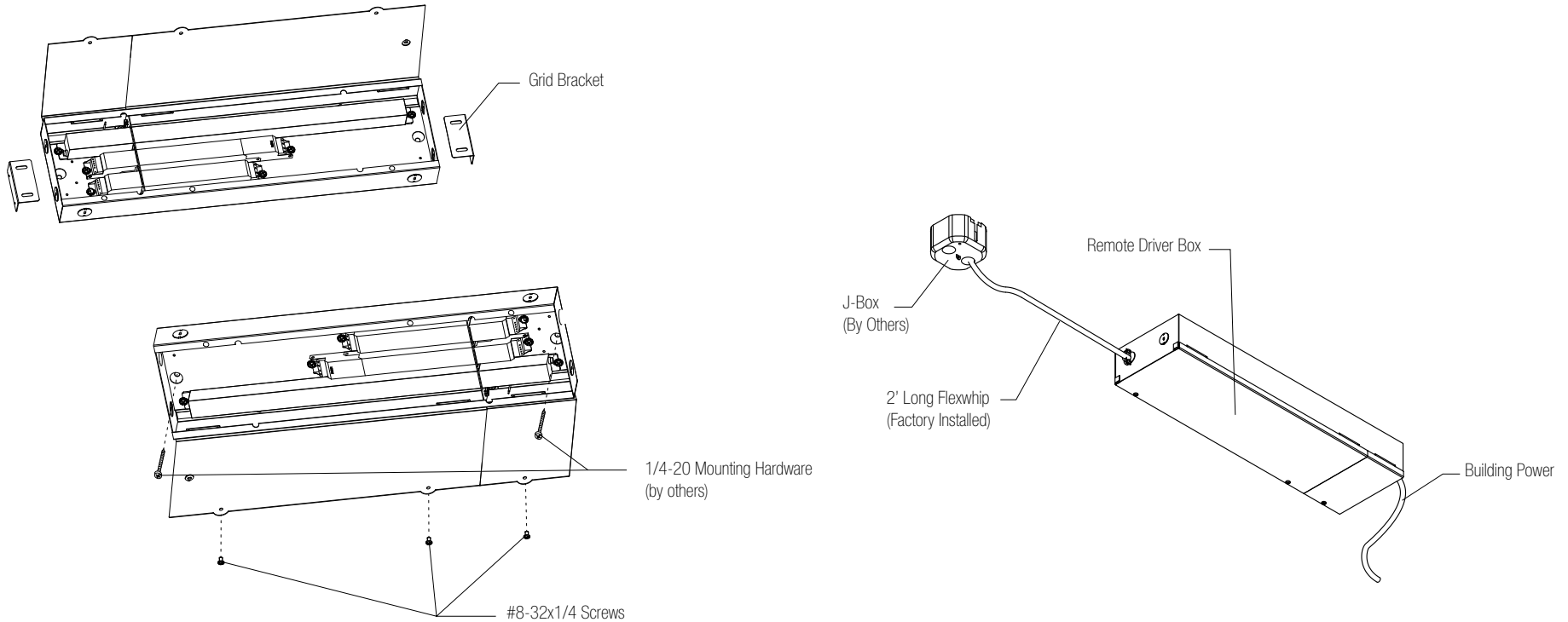
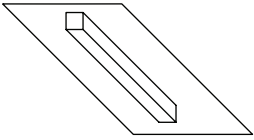

### Install Directions

1. Remove Grid Brackets on sides of Remote Driver Box.
2. Open Remote Driver Box by removing three #8-32x1/4 screws on top of box.
3. Install Remote Driver box to surface using 1/4-20 Mounting Hardware.
4. Use 1/2" Trade Knock out on high voltage side to connect to building power.
5. Use 2' long Flexwhip to bring power to J-Box.



1. This product must be installed in accordance with applicable installation and electrical codes by a professional familiar with the construction and operation of the product.
2. Minimum 90°C supply conductors
3. All electrical connections must be performed by a certified electrician to applicable local and national electrical codes.

4. Fixtures must be mounted directly to structure.
5. The holding strength of AC cables cannot be guaranteed if the cables are damaged in any way.
6. All of Pinnacle's packaging is recyclable with the exception of the straps on the pallets. Please reach out to the factory if you need assistance in recycling any packaging components.



# EDGE Evolution EX12

INACCESSIBLE CEILING  
CANOPY REMOTE BOX  
NEW CONSTRUCTION  
INSTALLATION

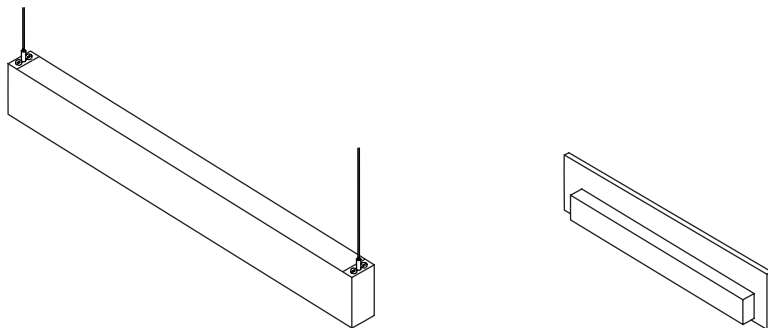

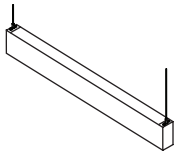

**Step 1:**  
Power Module Installation

1. Assemble the cross bars and power module together with the Crossbar Bracket and hex nuts. Fold the locking tab on the Crossbar Bracket over the crossbar.
2. Position and install the assembly between the ceiling joists as required.
3. Make necessary wiring connections in the Power Module between Building Power and Power to Remote Box. **(Power to Remote Box must be connected before ceiling is installed)**
4. Once ceiling is installed cut a 4-1/2" diameter hole in the ceiling aligned with the Power Module.
5. Pull Power to Remote Box through Bottom Ring and secure Bottom Ring to Power Module with provided 8-32x1-1/4" screws.

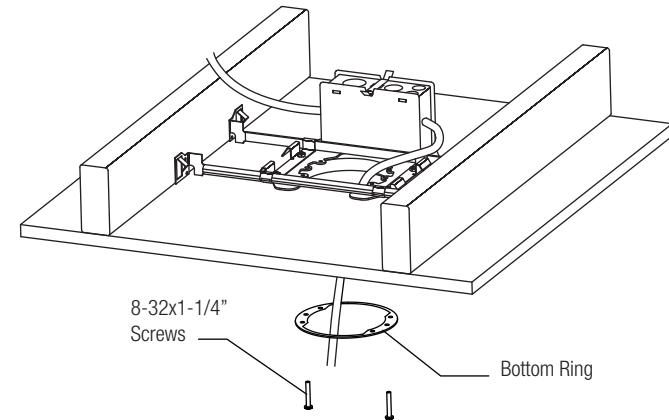
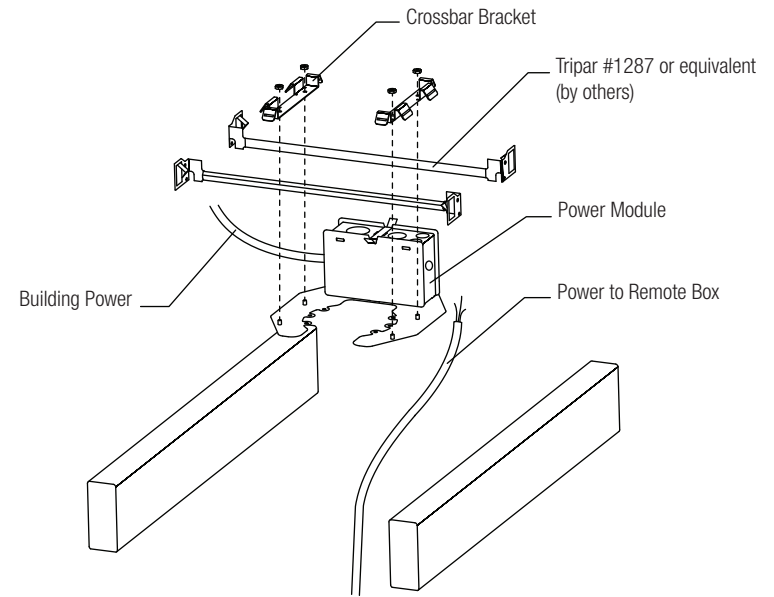
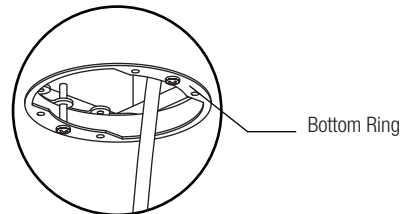
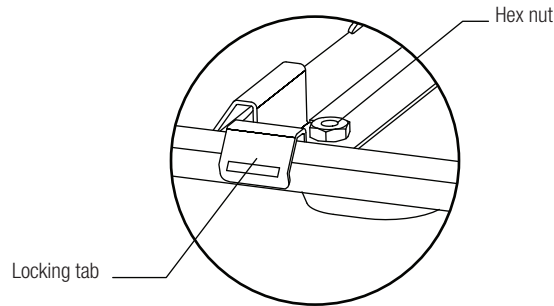

1. This product must be installed in accordance with applicable installation and electrical codes by a professional familiar with the construction and operation of the product.
2. Minimum 90°C supply conductors
3. All electrical connections must be performed by a certified electrician to applicable local and national electrical codes.

4. Fixtures must be mounted directly to structure.
5. The holding strength of AC cables cannot be guaranteed if the cables are damaged in any way.
6. All of Pinnacle's packaging is recyclable with the exception of the straps on the pallets. Please reach out to the factory if you need assistance in recycling any packaging components.

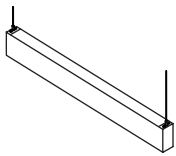

**Step 2:**  
Remote Box Wiring

1. Remove the four screws securing the Top Cover from the Remote Box. Using one of the knock outs on the top cover, run the cord from the power module into the Remote Box and make connections to the Driver as needed.
2. Run SJT from fixture into Remote Box and make connections to Driver as needed.
3. Once all wiring connections are made, replace Top Cover and slide Remote Box through the ceiling opening and into place. (Push most of the flexwhip through the bottom ring first)
4. Secure Remote Box into place using provided 10-32x1-1/4" Screws.
5. Slide cord to fixture through Canopy and use the AC Gripper to secure the Canopy to Remote Box.

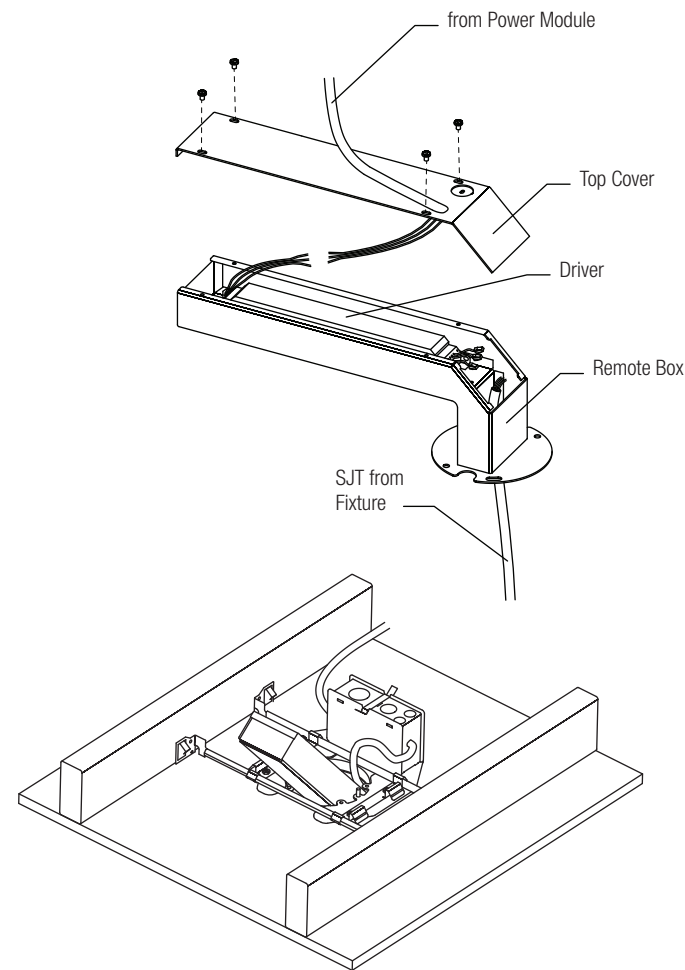
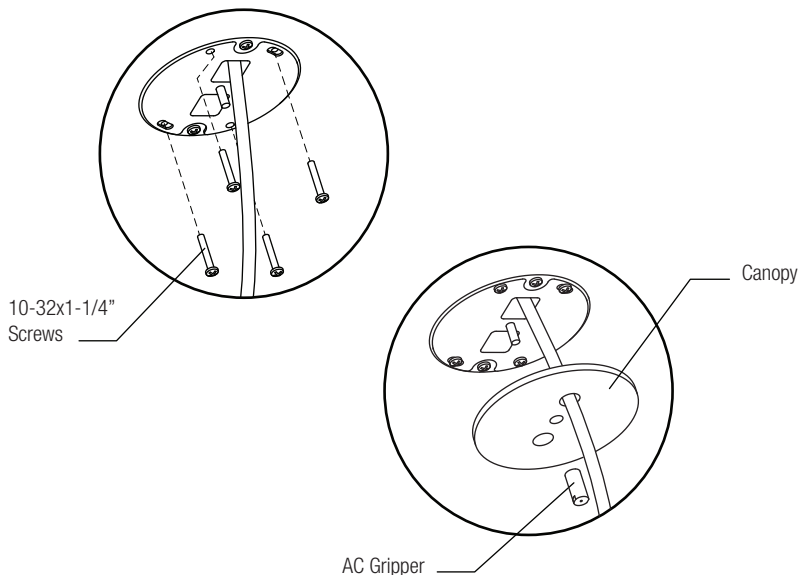

AC cables with damage, bends, kinks, fraying, or knots must be discarded and replaced with new components. Never install a fixture where the AC cable is more than 5 degrees from perpendicular to the fixture. Fixtures are never to be raised by the cables (instead, lift the fixture up and adjust the cable position). Overtightening of hardware on grippers can damage AC cables. Never exert force down onto the top of the fixture once it is hanging by safety cables. Never cut safety cables prior to installation. The first zip tie on the SJT and AC cables below the ceiling/canopy must be no closer than 12" from the ceiling/canopy.



1. This product must be installed in accordance with applicable installation and electrical codes by a professional familiar with the construction and operation of the product.
2. Minimum 90°C supply conductors
3. All electrical connections must be performed by a certified electrician to applicable local and national electrical codes.

4. Fixtures must be mounted directly to structure.
5. The holding strength of AC cables cannot be guaranteed if the cables are damaged in any way.
6. All of Pinnacle's packaging is recyclable with the exception of the straps on the pallets. Please reach out to the factory if you need assistance in recycling any packaging components.



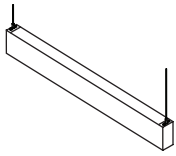

# EDGE EVOLUTION EX12

# New Construction AC - to - JB Mount

Return to Main Menu

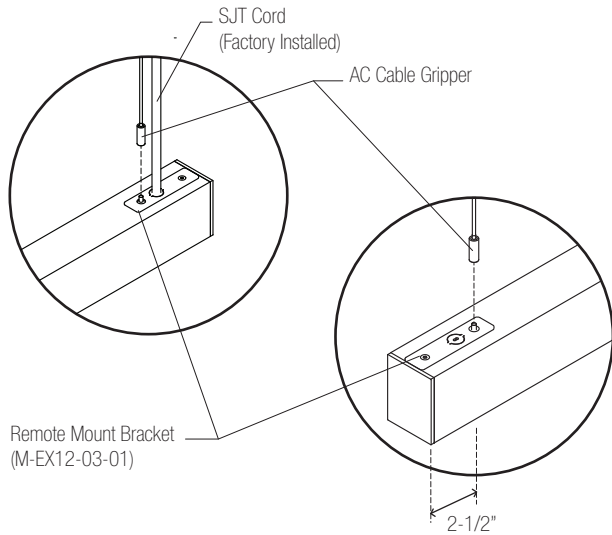

### Step 3: AC Mounting

#### Power Side

1. Attach AC Cable Gripper to stud on top of housing.

#### Non power Side

1. Attach AC Cable Gripper to Stud on top of housing.
2. Once both sides are hung level fixture.

### Mount Spacing

Aircraft Cable - Example Rows

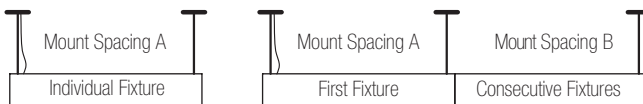

Length	A	B
2'	19"	24"
3'	31"	36"
4'	43"	48"
5'	55"	60"
6'	67"	72"
7'	79"	84"
8'	91"	96"

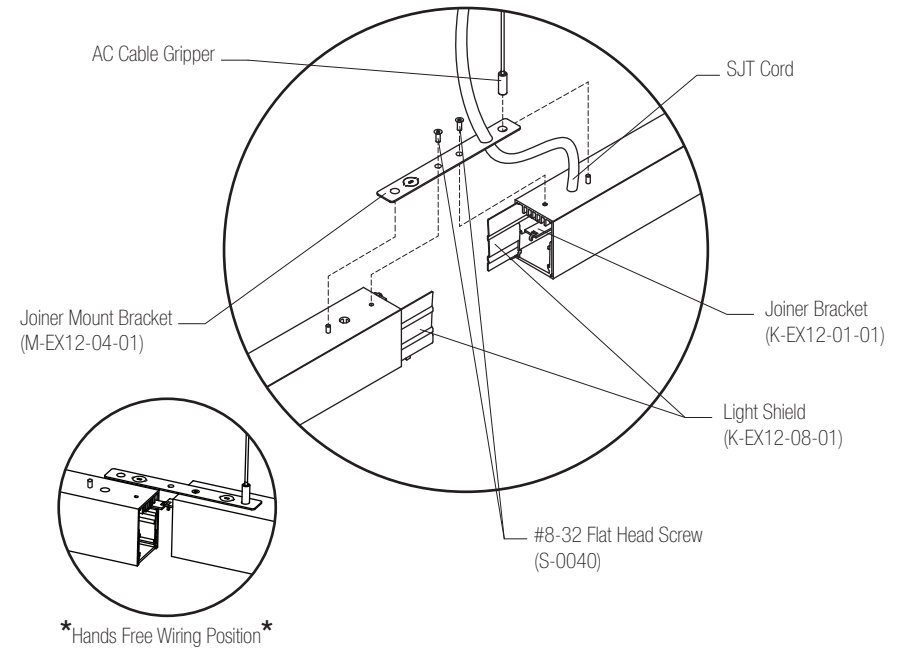

### Step 4: Joining Fixtures

1. If SJT Cable is present, feed SJT Cable through knockout in Joiner Bracket.
2. Attach Joiner Mount Bracket to incoming fixture using provided #8-32 Flat Head Screw.
3. Hang fixture via AC Cable Gripper and stud protruding from fixture through Joiner Mount Bracket.
4. Hook fixtures together into the Hands Free Wiring Position via joiner bracket.
5. Make all necessary wiring connections between fixtures.
6. Unhook fixtures and slide together using Light Shields for alignment.
7. Secure subsequent fixture and Joiner Mount Bracket with #8-32 Flat Head Screw.
8. Hang fixture via AC Cable Gripper and stud protruding from fixture through Joiner Mount Bracket.



1. This product must be installed in accordance with applicable installation and electrical codes by a professional familiar with the construction and operation of the product.  
 2. Minimum 90°C supply conductors  
 3. All electrical connections must be performed by a certified electrician to applicable local and national electrical codes.

4. Fixtures must be mounted directly to structure.  
 5. The holding strength of AC cables cannot be guaranteed if the cables are damaged in any way.  
 6. All of Pinnacle's packaging is recyclable with the exception of the straps on the pallets. Please reach out to the factory if you need assistance in recycling any packaging components.



# EDGE Evolution EX12

INACCESSIBLE CEILING  
CANOPY REMOTE BOX  
RETROFIT  
INSTALLATION

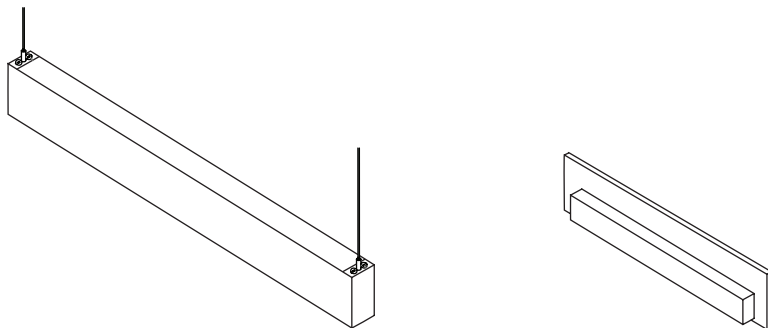

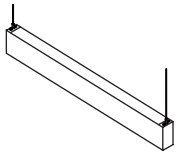

**Step 1:**  
Remote Box Prep

1. Cut 4-1/2" diameter hole in ceiling.
1. Run building power to Power Module, make necessary wiring connections between building power and Power to Remote Box.
2. Remove the four screws from the Top Cover of the Remote Box.
3. Run cable from Power Module into knockout on Top Cover of Remote Box and make wiring connections to Driver.
4. Run SJT Cable from Fixture through 5" Power Canopy and into Remote Box, make wiring connections to Driver.
5. Reattach Top Cover once all wiring connections are made.

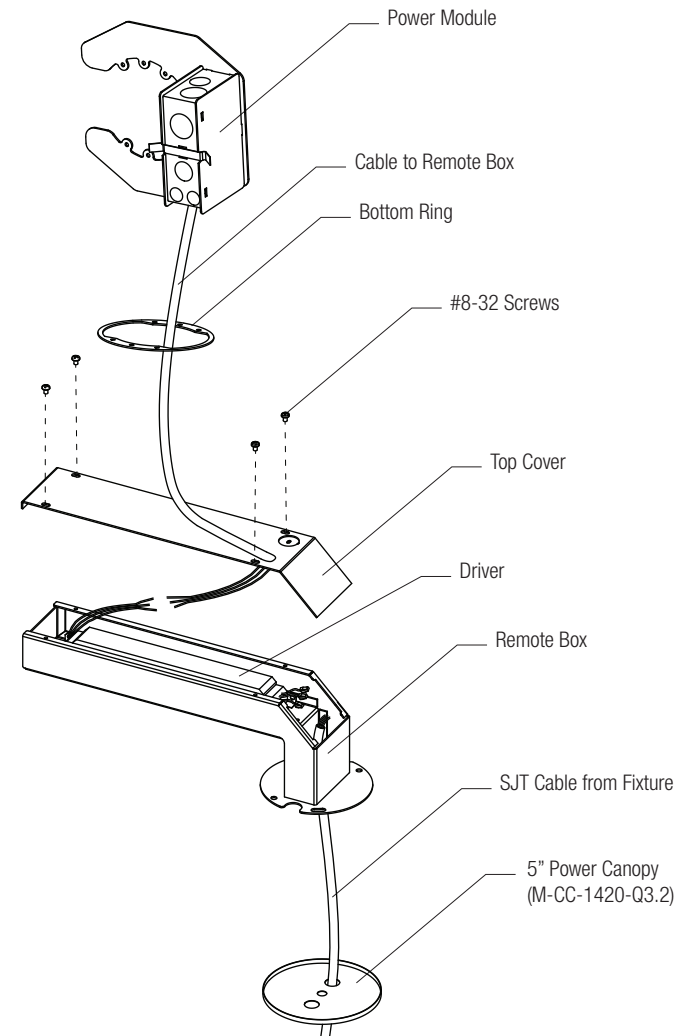

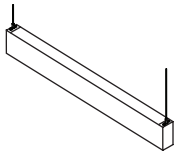

**Step 2:**  
Installing J Box Base

1. Insert Power Module through hole and into ceiling using a twisting motion.
2. Position Power Module above hole and secure using Bottom Ring, and secure using two 10-32x1-1/4" screws.

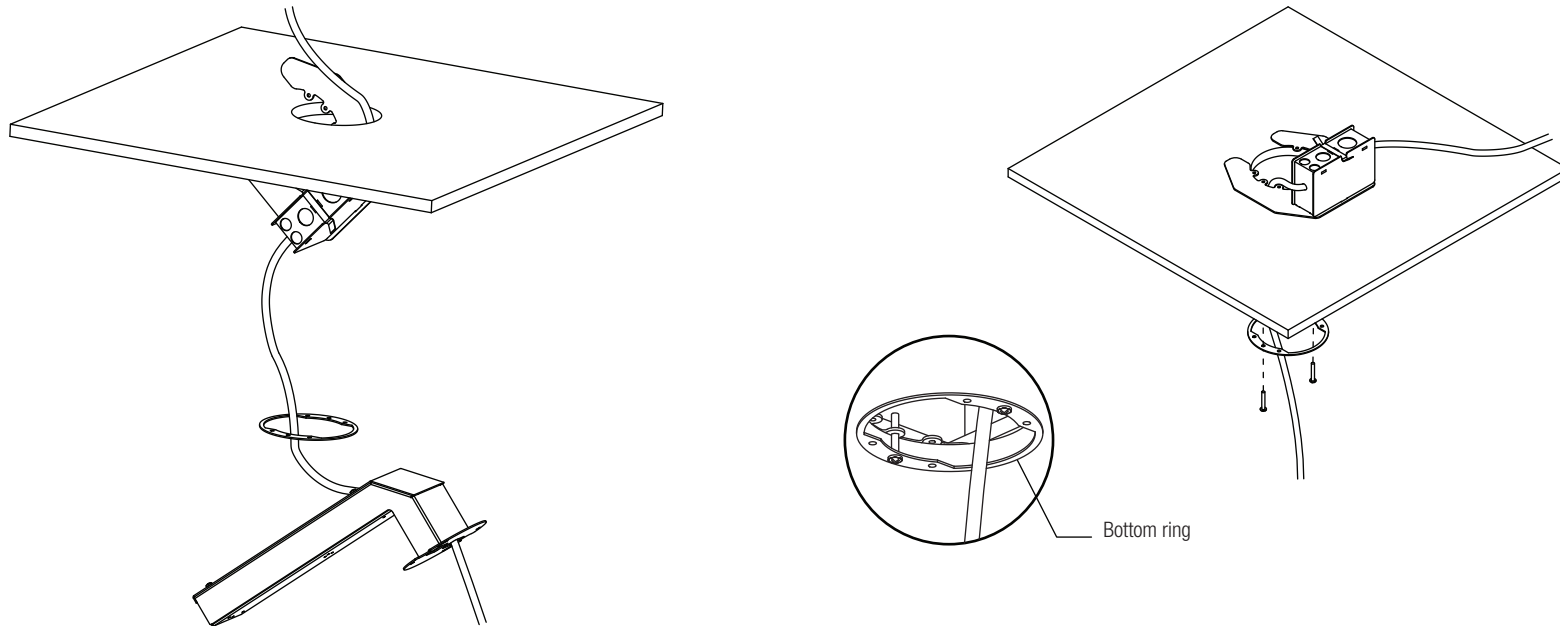

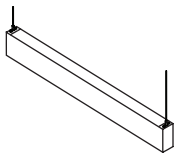

**Step 2:**  
Installing J Box Base

1. Slide Remote Box into hole in ceiling. (push most of the flexwhip through first)
2. Secure Remote Box into place using provided 10-30x1-1/4" Screws.
3. Slide cord to fixture through Canopy and use the AC Gripper to secure the Canopy to Remote Box.

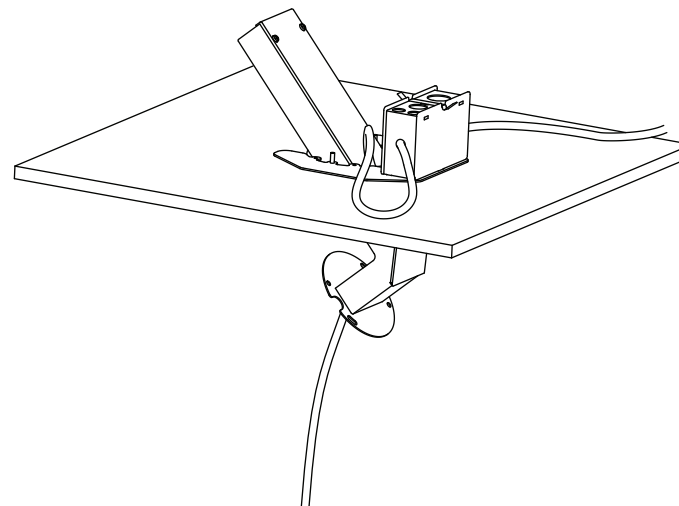
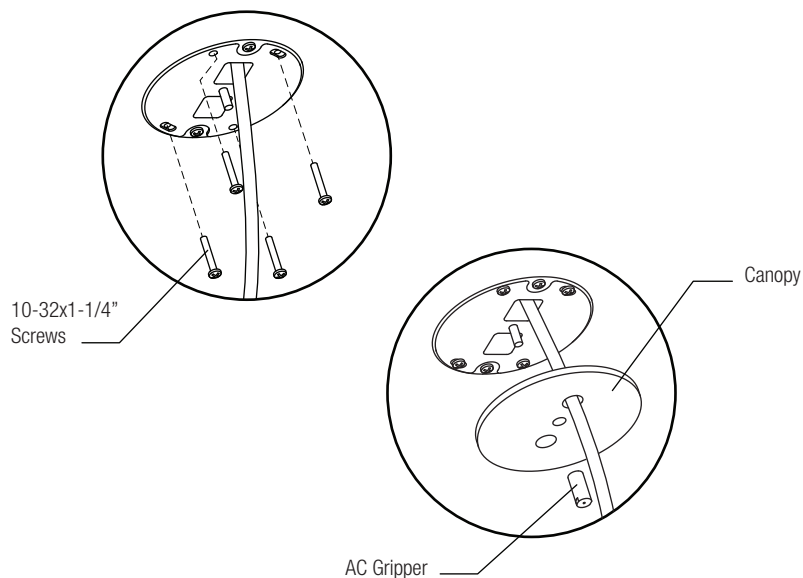



# EDGE Evolution EX12

INACCESSIBLE CEILING  
CANOPY REMOTE BOX  
REMOTE BOX TO FIXTURE  
INSTALLATION

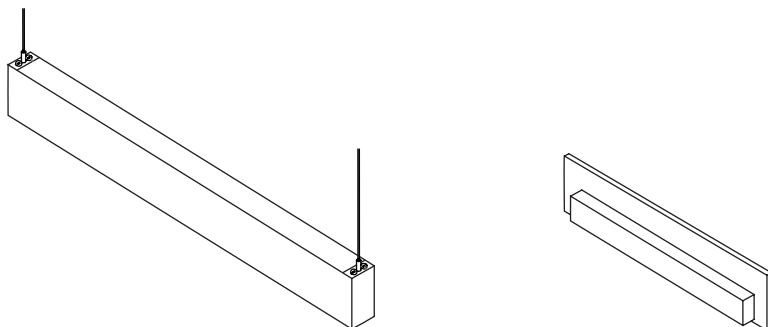

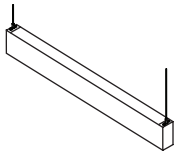

# EDGE EVOLUTION EX12 AC - to - JB Mount

Return to Main Menu

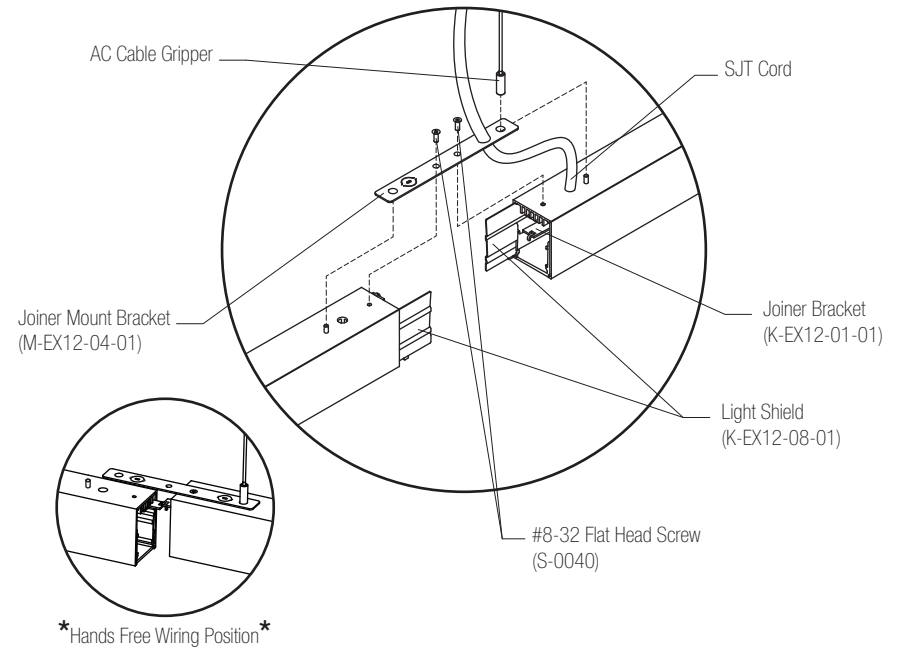
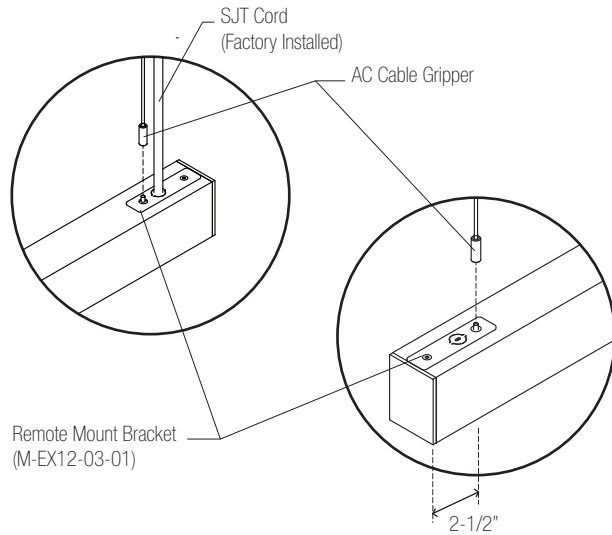

### Step 3: AC Mounting

#### Power Side

1. Attach AC Cable Gripper to stud on top of housing.

#### Non power Side

1. Attach AC Cable Gripper to Stud on top of housing.
2. Once both sides are hung level fixture.

### Mount Spacing

Aircraft Cable - Example Rows

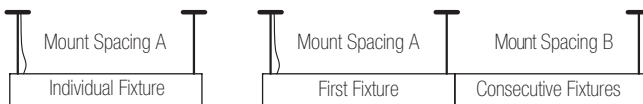

Length	A	B
2'	19"	24"
3'	31"	36"
4'	43"	48"
5'	55"	60"
6'	67"	72"
7'	79"	84"
8'	91"	96"

### Step 4: Joining Fixtures

1. If SJT Cable is present, feed SJT Cable through knockout in Joiner Bracket.
2. Attach Joiner Mount Bracket to incoming fixture using provided #8-32 Flat Head Screw.
3. Hang fixture via AC Cable Gripper and stud protruding from fixture through Joiner Mount Bracket.
4. Hook fixtures together into the Hands Free Wiring Position via joiner bracket.
5. Make all necessary wiring connections between fixtures.
6. Unhook fixtures and slide together using Light Shields for alignment.
7. Secure subsequent fixture and Joiner Mount Bracket with #8-32 Flat Head Screw.
8. Hang fixture via AC Cable Gripper and stud protruding from fixture through Joiner Mount Bracket.



1. This product must be installed in accordance with applicable installation and electrical codes by a professional familiar with the construction and operation of the product.  
 2. Minimum 90°C supply conductors  
 3. All electrical connections must be performed by a certified electrician to applicable local and national electrical codes.

4. Fixtures must be mounted directly to structure.  
 5. The holding strength of AC cables cannot be guaranteed if the cables are damaged in any way.  
 6. All of Pinnacle's packaging is recyclable with the exception of the straps on the pallets. Please reach out to the factory if you need assistance in recycling any packaging components.



# EDGE Evolution EX12

LENS  
DETAIL

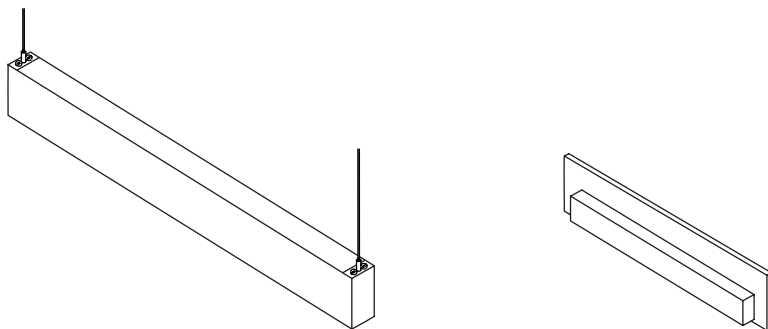



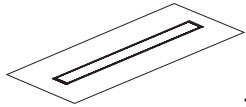

## Lens Installation

1. Begin at one end of the lens and squeeze sides to allow it to flex.
2. Insert end of lens into place. Lens snaps into place when installed properly.
3. Slowly insert rest of lens down the length of the fixture.

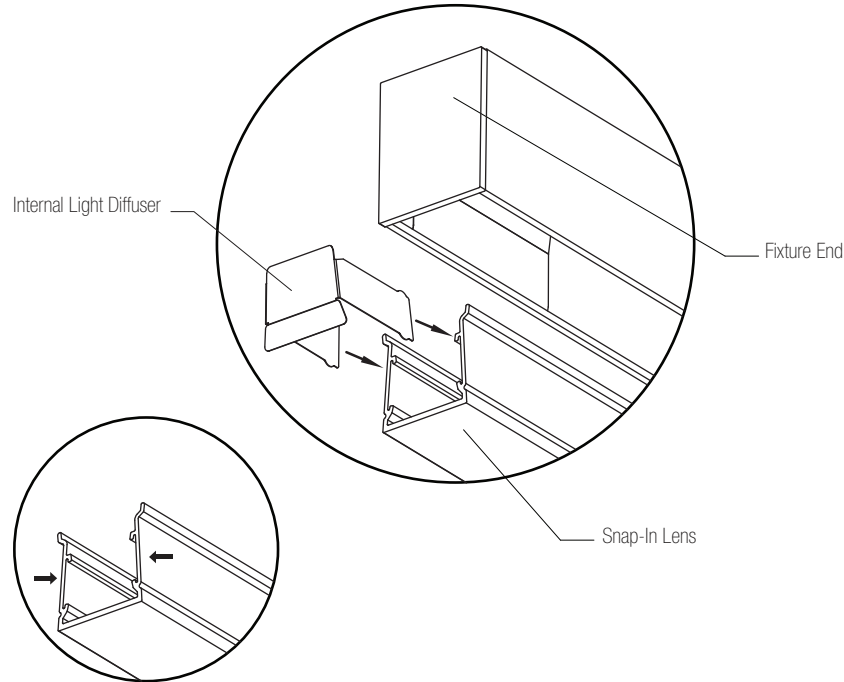

## Lens Removal

1. Insert a rigid object approx. 1/16" thick, such as a putty knife, into the edge between the lens and the fixture side about one inch from end.
2. Using said object, gently pry lens away from fixture until it is released from the mounting groove.
3. Once the section is released, start at that end of the fixture and pull the lens out of the fixture.

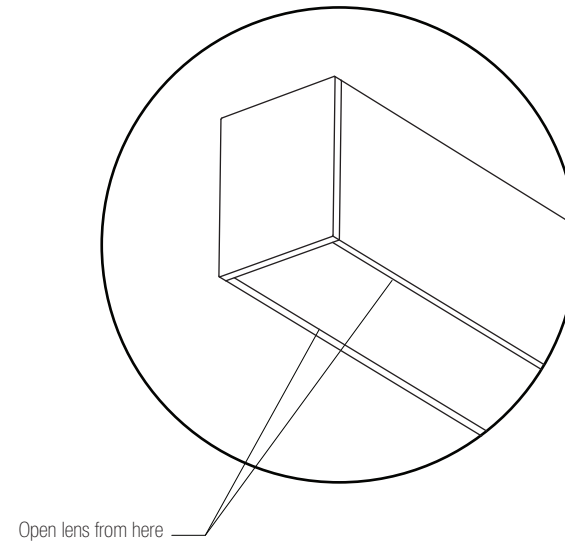

**Note: Low temperatures can affect the lens material, making it brittle. Please allow the lenses to warm to room temperature before installation.**