



## EDGE Evolution Fixtures



EV3D-WW

Grid Installation .....	2
Flanged (FL) Inaccessible Installation .....	3-4
Non-Flanged (NF) Inaccessible Installation .....	5-6
Spackle Flange Inaccessible Installation .....	7
Rotating Crossbar Inaccessible Installation .....	8



### 1 GRID PREPARATION AND INSTALLATION

Prepare grid to the width needed to accommodate the fixture. Place fixture into grid opening and tie off fixture to support.

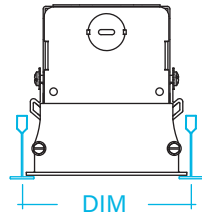
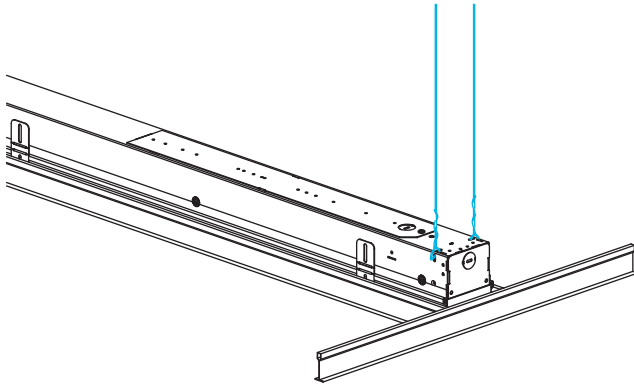

DIM G9/GS	DIM G1
4"	4-1/4"

### 2 POWER

Remove Access Plate via one screw. Make wiring connections to building power and replace Access Plate.

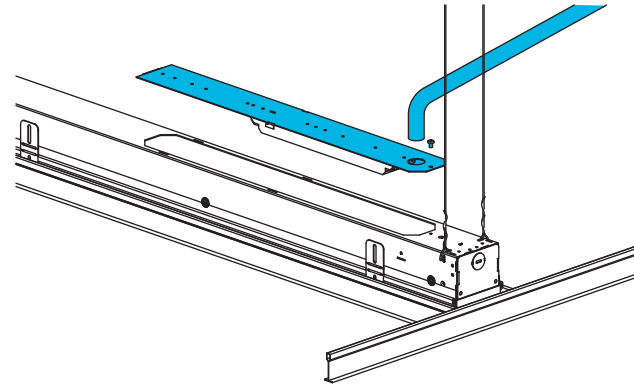

### 3 JOINING

Make wiring connections between fixtures, tap joining biscuit in to one fixture, slide fixtures together, and secure using joining bracket and four screws.

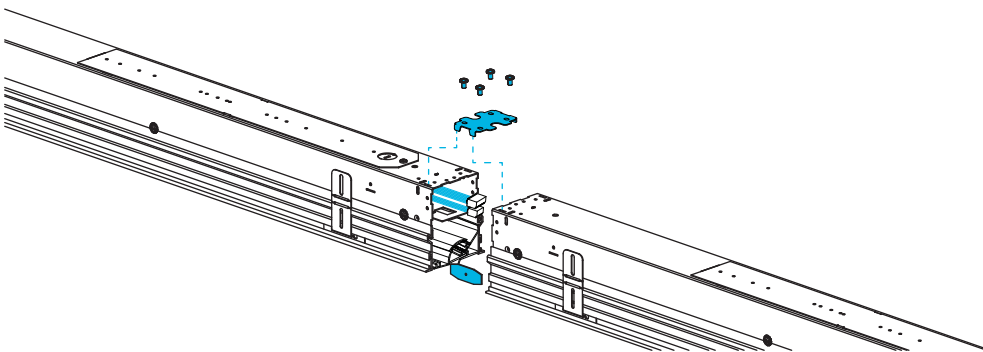

### 4 SECURING TO GRID

Center fixture on grid, bend grid brackets over and fasten to grid.

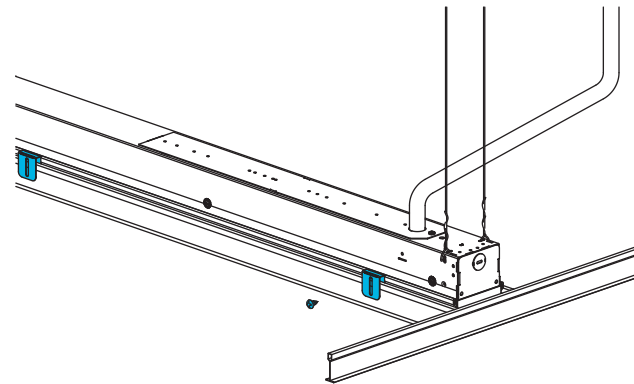



### 1 LAYOUT & DIMENSIONS

Rough in fixture opening and install 1/4" hardware (by others) according to tables to the right. Fixture length can be found on label inside fixture.

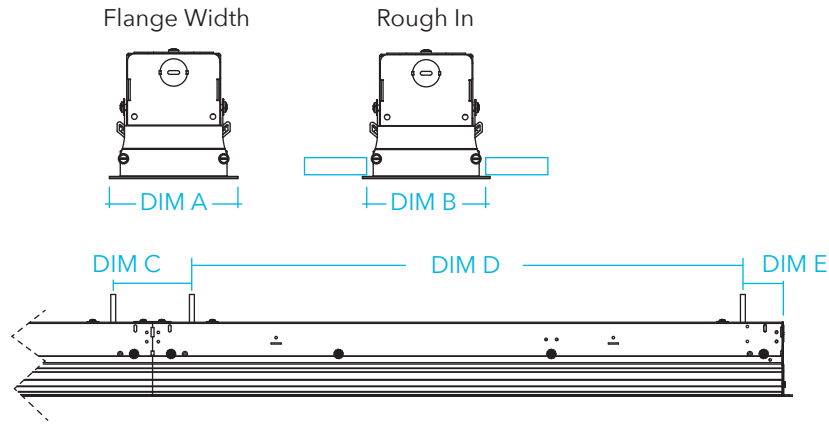

#### ROUGH - IN

DIM A	DIM B
4-1/8"	3-5/8"

Rough-in for length is  
Row or Fixture Length + 3/8"

#### THREADED ROD LOCATIONS

LENGTH	DIM C	DIM D	DIM E
23"	3/4"	21-1/2"	13/16"
24"	3/4"	22-1/2"	13/16"
35"	2-5/8"	29-3/4"	2-11/16"
36"	2-5/8"	30-3/4"	2-11/16"
47"	2-5/8"	41-3/4"	2-11/16"
48"	2-5/8"	43-3/4"	2-11/16"
59"	2-5/8"	53-3/4"	2-11/16"
60"	2-5/8"	54-3/4"	2-11/16"
71"	1-5/8"	66-3/4"	2-11/16"
72"	2-5/8"	66-3/4"	2-11/16"
83"	1-5/8"	78-3/4"	2-11/16"
84"	1-5/8"	79-3/4"	2-11/16"
95"	1-5/8"	90-3/4"	2-11/16"
96"	2-5/8"	90-3/4"	2-11/16"

### 2 POWER

Remove Access Plate via one screw. Make wiring connections to building power and replace Access Plate.

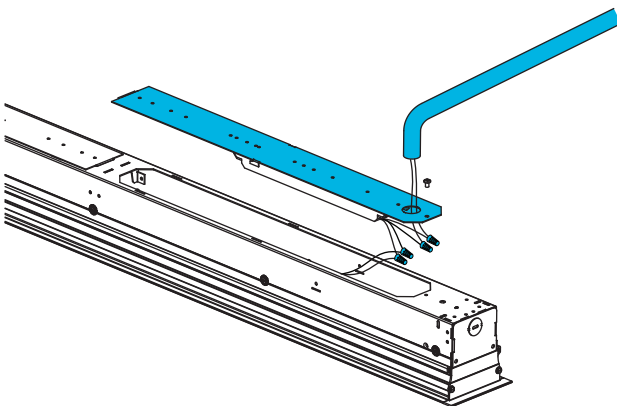

### 3 INDIVIDUAL FIXTURE

Starting at one end remove wall wash module by pulling entire module out of fixture. Disconnect reflector wiring. Mount fixture through mounting slot to 1/4" hardware (by others).

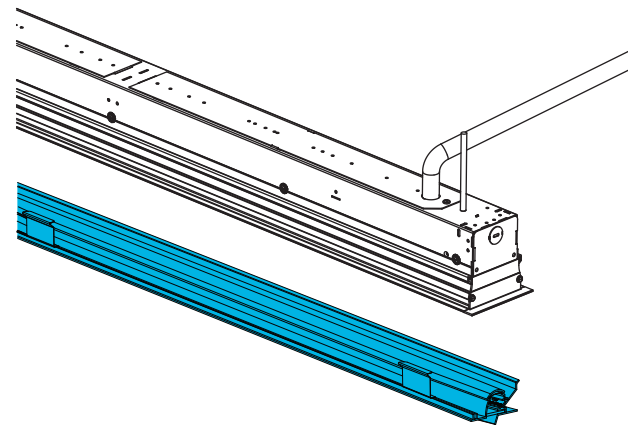



### 4 JOINING FIXTURES

Starting at one end remove wall wash module by pulling entire module out of fixture. Make wiring connections between fixtures, tap joining biscuit in to one fixture, slide fixtures together, and secure using joining bracket and four screws.

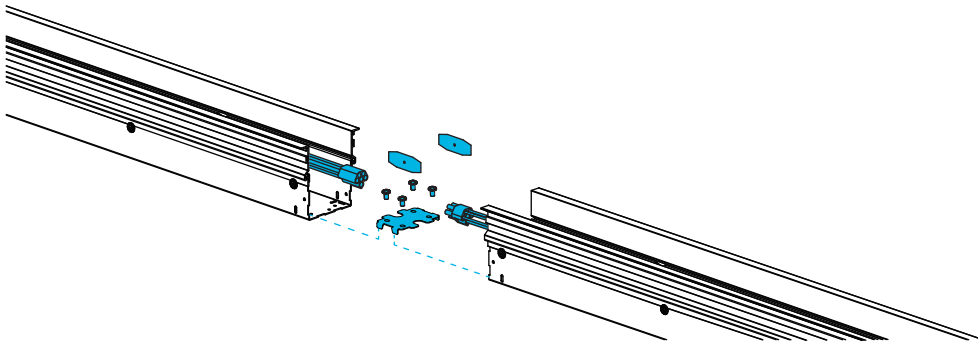

### 5 FINISHING

Re-install wall wash module by inserting extruded leg first then pinching in steel leg and inserting into housing. Push module into housing, you will hear the steel leg snap into place.

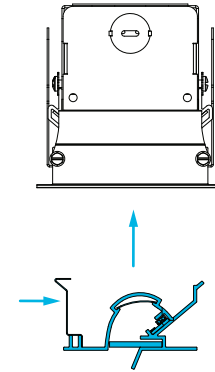



### 1 LAYOUT & DIMENSIONS

Rough in fixture opening and install 1/4" hardware (by others) according to tables to the right. Fixture length can be found on label inside fixture.

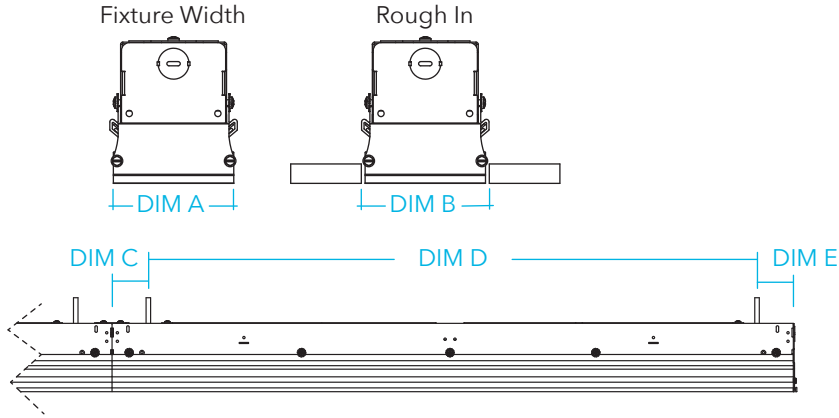

#### ROUGH - IN

DIM A	DIM B
3-7/16"	3-5/8"

Rough-in for length is  
Row or Fixture Length + 3/8"

#### THREADED ROD LOCATIONS

LENGTH	DIM C	DIM D	DIM E
23"	3/4"	21-1/2"	13/16"
24"	3/4"	22-1/2"	13/16"
35"	2-5/8"	29-3/4"	2-11/16"
36"	2-5/8"	30-3/4"	2-11/16"
47"	2-5/8"	41-3/4"	2-11/16"
48"	2-5/8"	43-3/4"	2-11/16"
59"	2-5/8"	53-3/4"	2-11/16"
60"	2-5/8"	54-3/4"	2-11/16"
71"	1-5/8"	66-3/4"	2-11/16"
72"	2-5/8"	66-3/4"	2-11/16"
83"	1-5/8"	78-3/4"	2-11/16"
84"	1-5/8"	79-3/4"	2-11/16"
95"	1-5/8"	90-3/4"	2-11/16"
96"	2-5/8"	90-3/4"	2-11/16"

### 2 POWER

Remove Access Plate via one screw. Make wiring connections to building power and replace Access Plate.

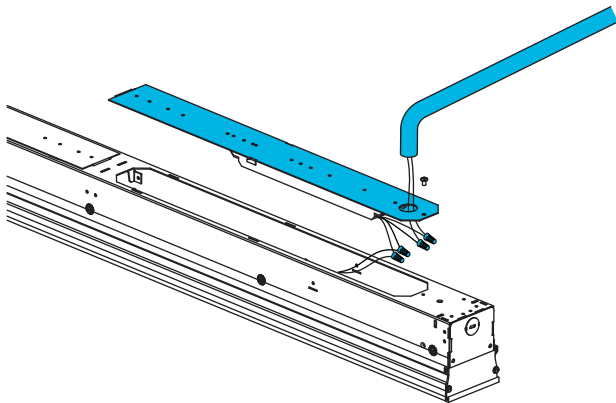

### 3 INDIVIDUAL FIXTURE

Starting at one end remove wall wash module but pulling entire module out of fixture. Disconnect reflector wiring. Mount fixture through mounting slot to 1/4" hardware (by others).

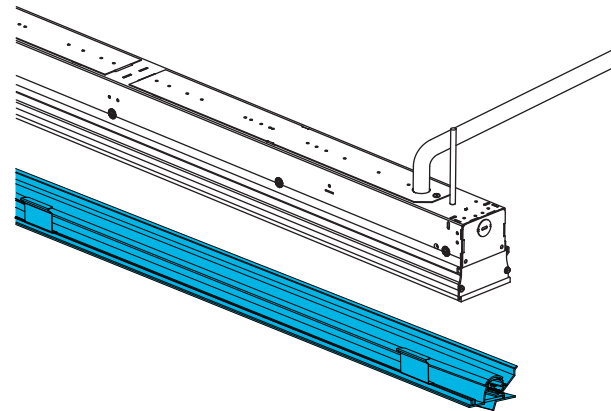



### 4 JOINING FIXTURES

Starting at one end remove wall wash module by pulling entire module out of fixture. Make wiring connections between fixtures, tap joining biscuit in to one fixture, slide fixtures together, and secure using joining bracket and four screws.

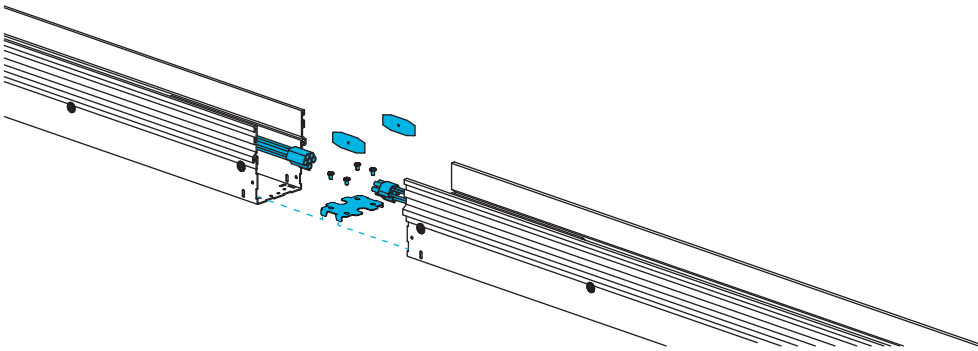

### 5 FINISHING

Re-install wall wash module by inserting extruded leg first then pinching in steel leg and inserting into housing. Push module into housing, you will hear the steel leg snap into place.

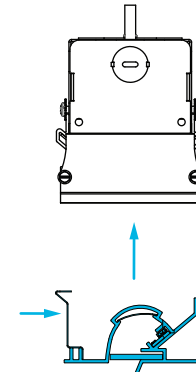



### 1 DIMENSIONS AND LAYOUT

Rough in fixture opening according to the table below, fixture length can be found on label inside fixture.  
*(Note: Do not screw in to side of housing. Do not remove cross brackets until fixture is installed.)*

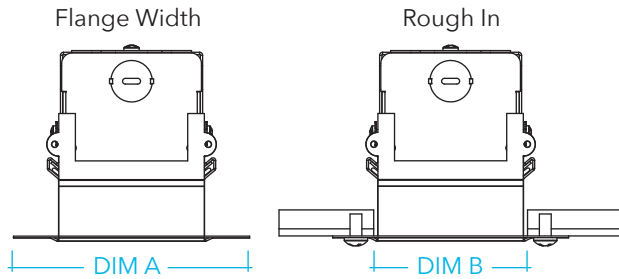

ROUGH - IN	
DIM A	DIM B
5"	3-5/8"

*Rough-in for length is  
Row or Fixture Length + 3/8"*

### 3 INDIVIDUAL FIXTURE

Mount fixture in rough-in opening by placing a screw behind each cross bracket along the length of the fixture and two on each end flange. Once mounted, remove cross brackets and discard. If individual fixture install lens.

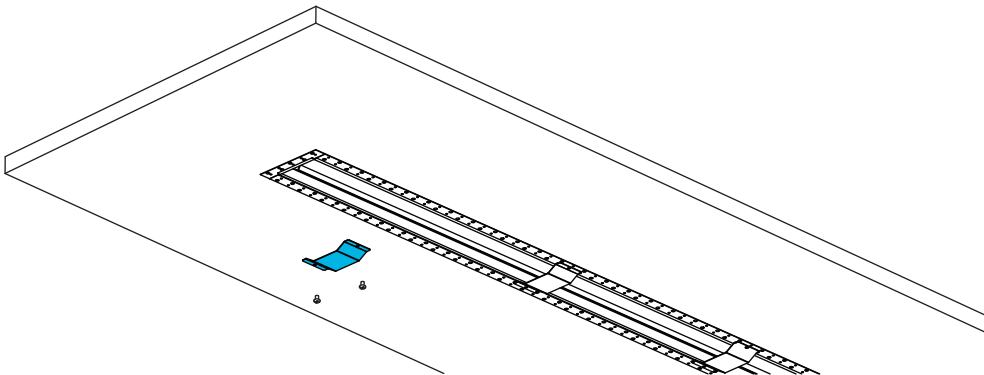

### 2 POWER

Remove Access Plate via one screw. Make wiring connections to building power and replace Access Plate.

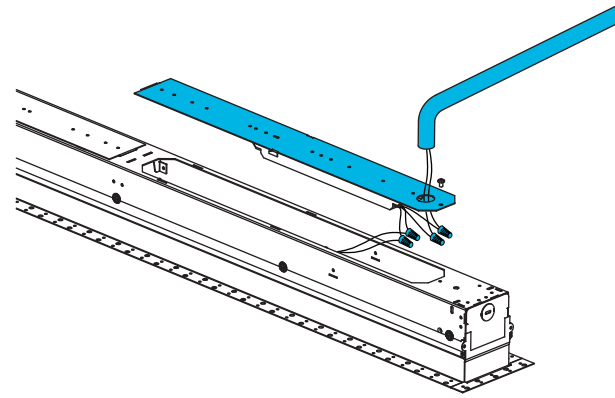

### 4 JOINING

Starting at one end remove wall wash module by pulling entire module out of fixture. Make wiring connections between fixtures, slide fixtures together, and secure using joining bracket and four screws. Once fixtures are joined re-install wall wash module by inserting extruded leg first then pinching in steel leg and inserting into housing. Push module into housing, you will hear the steel leg snap into place.

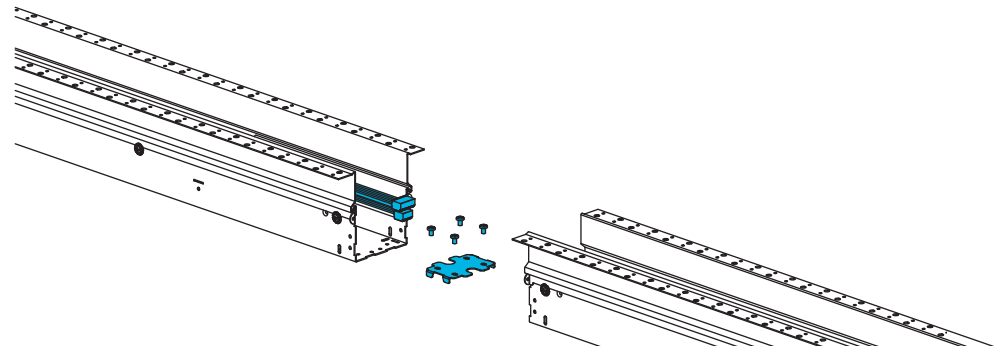



### 1 LAYOUT & DIMENSIONS

Rough in Fixture opening according to table. Fixture length can be found on fixture label inside fixture.

Flange Width

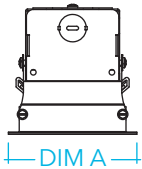

Rough In

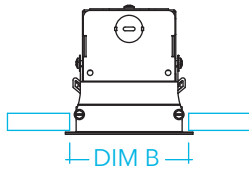

#### ROUGH - IN

MOUNTING	DIM A	DIM B
FL	4-1/8"	3-5/8"
NF	3-7/16"	3-5/8"

*Rough-in for length is  
Row or Fixture Length + 3/8"*

### 3 INDIVIDUAL FIXTURE

Starting at one end remove wall wash module by pulling entire module out of fixture. Slide fixture into rough-in opening and rotate crossbar to lock in place using 1/4-20 screw inside fixture. If individual fixture replace wall wash module by inserting extruded leg first then pinching in steel leg and inserting into housing. Push module into housing, you will hear the steel leg snap into place.

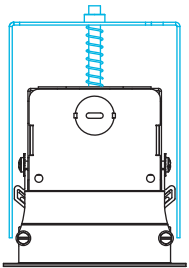

Before Installation

1/2" - 5/8"  
drywall

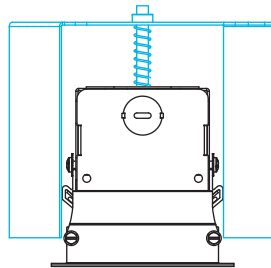

After Installation

### 2 POWER

Remove Access plate via one screw. Make wiring connections to building power and replace Access Plate.

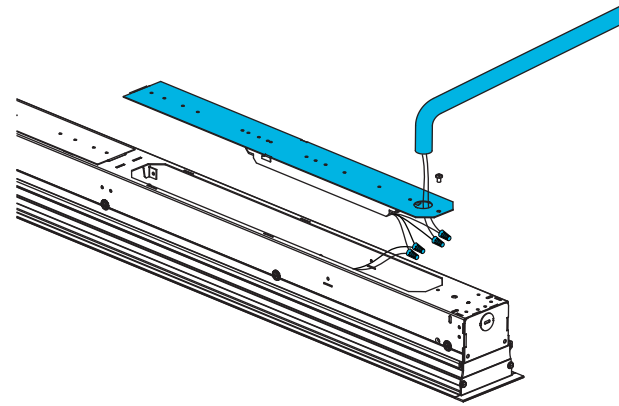

### 4 JOINING

Starting at one end remove wall wash module by pulling entire module out of fixture. Make wiring connections between fixtures, tap joining biscuit in to one fixture, slide fixtures together, and secure using joining bracket and four screws. Once fixtures are joined re-install wall wash module by inserting extruded leg first then pinching in steel leg and inserting into housing. Push module into housing, you will hear the steel leg snap into place.

